

LNG CARRIER APPROVAL & VETTING PROCEDURES FOR LNG CARRIERS CALLING AT TERMINAL OFFSHORE LNG TOSCANA S.p.A. (OLT)

WAIVER: The following LNG Carrier Approval & Vetting Procedures are subject to further amendments, they are disclosed only for information purposes and shall not be binding in any manner on OLT S.p.A., its affiliates, parent companies, representative and counsel involved in its preparation and approval. The following LNG Carrier Approval & Vetting Procedures were prepared by OLT S.p.A. exercising all reasonable care. However, OLT S.p.A., its affiliates, parent companies, representative and counsel involved in its preparation and approval shall not be liable or otherwise responsible for their use -even partial -and any damages or losses resulting out of their use in any case (individual or not) and in whatever jurisdiction.

Index

1.0 Introduction	4
1.1 USING THIS DOCUMENT	5
1.2 REGULATORY REQUIREMENTS	6
2.0 General Information	7
2.1 GENERAL INFORMATION ON LNG CARRIER APPROVAL PROCEDURES.....	8
2.2 STRUCTURE OF THE APPROVAL PROCESS.....	9
3.0 Compatibility Approval Steps.....	10
3.1 STEP 1 –PREPARATORY INFORMATION	11
3.2 STEP 2 – LNG CARRIER / TERMINAL COMPATIBILITY STUDY	14
3.3 STEP 3 –LNG CARRIER SAFETY INSPECTION	17
3.4 STEP 4 –UNLOADING TEST AND LNG CARRIER COMPATIBILITY APPROVAL.....	18
3.5 STEP 5 –LNG CARRIER COMPATIBILITY APPROVAL FOLLOW-UP	20
4.0 Quality Approval Process	21
4.1 QUALITY VETTING REQUIREMENTS	22
4.2 REJECTED LNG CARRIERS	23
4.3 THE ELEMENTS OF QUALITY VETTING	24
5.0 Ship Inspection Report Program (SIRE) Inspections	25
5.1 OVERVIEW OF SIRE AND APPLICATION TO TERMINAL	26
5.2 SIRE INSPECTIONS	27
5.3 INCIDENT REPORTING	28
5.4 TERMINAL FEEDBACK REPORTS	29
6.0 LNG Carrier / Terminal Compatibility	30
6.1 SPECIFIC LNG CARRIER REQUIREMENTS FOR THE TERMINAL	31
A. Topics for Preliminary Meetings.....	33
Glossary.....	35
CONFIRMATION LIST OF LNG CARRIER OPERATOR FOR THE PERFORMANCE OF COMPATIBILITY STUDY	37

APPENDIX 1: ARRANGEMENT OF SHIP'S PARALLEL BODY AND FENDERS **Errore. Il segnalibro non è definito.**

APPENDIX 2: LAYOUT OF FAIRLEAD – MOORING WINCHES..... **Errore. Il segnalibro non è definito.**

APPENDIX 3: BERTHING ENERGY AND STATIC MOORING CALCULATIONS **Errore. Il segnalibro non è definito.**

APPENDIX 4: MANIFOLD FREE SPACE ENVELOPE FOR FITTING OF THE TARGETING CONE + LNGC
DISTANCE PIECES **Errore. Il segnalibro non è definito.**

APPENDIX 4: MANIFOLD FREE SPACE ENVELOPE FOR FITTING OF THE TARGETING CONE + LNGC
DISTANCE PIECES **Errore. Il segnalibro non è definito.**

APPENDIX 5: POOR WEATHER DEPARTURE..... **Errore. Il segnalibro non è definito.**

1.0 Introduction

OVERVIEW

Introduction

This *LNG Carrier Approval & Vetting Procedures* document sets out the approval process of LNG Carriers nominated to berth, deliver LNG, and un-berth at the Terminal.

This chapter describes the scope and purpose of this document. It also contains other basic information, such as who the intended reader/users are, how the document is organized and who has control and custody of it.

In this chapter

This chapter contains the following information:

1.1 Using This Document

1.2 Regulatory Requirements

1.1 USING THIS DOCUMENT

Purpose

This document provides guidance for the approval process for LNG Carriers nominated to call at the Terminal

Scope

This document describes the approval process for all LNG Carriers nominated to call at the Terminal.

Readers

This document is to be used by OLT, the Terminal Operator, the Users, the LNG Carrier owners/charterers and crew and the LNG Carrier Operators and the following key personnel:

- Operations Manager
 - Commercial Manager
 - Terminal Manager
 - Marine Superintendent
-

Document organization

Document organization follows these guidelines:

- This document is organized by chapters.
 - The 'Table of Contents' at the front of the document lists chapter titles and the sections and topics of each chapter.
 - Each chapter includes a table of contents that lists the sections and topics within that chapter.
-

Document Owner

OLT has overall custody and control of the LNG Carrier Approval & Vetting Procedures and is responsible for any subsequent changes made to them.

Changes/Amendments

OLT reserves the right to amend the LNG Carrier Approval & Vetting Procedures from time-to-time without prior notice or consultation.

1.2 REGULATORY REQUIREMENTS

Acts and regulations:

For example but not limited to :

Maritime Safety Regulations Nr. 6/2014 issued by the Livorno Harbor Master on January 29th 2014, updated time-to-time.

Authority for Electricity and Gas, resolution n. 167/05 dated 1st August 2005 as updated from time to time.

D.M. 02/08/2007 – Ministry of Transport “Norme provvisorie per il trasporto marittimo alla rinfusa delle merci pericolose allo stato gassoso, norme per gli allibi e procedure amministrative per il rilascio dell’autorizzazione all’imbarco ed il nulla osta allo sbarco delle merci medesime”

2.0 General Information

OVERVIEW

Introduction

This chapter provides an overview of the LNG Carrier approval process

In this chapter

This chapter contains the following information:

2.1 General Information on LNG Carrier Approval Procedures

2.2 Structure of the Process

2.1 GENERAL INFORMATION ON LNG CARRIER APPROVAL PROCEDURES

Introduction

The purpose of these vetting/approval procedures is to establish a structured process that evaluates the LNG Carrier's capability safely and efficiently to deliver LNG to the Terminal. This is referred to as the "**Approval Process**" and consists of two different activities:

- compatibility with the Terminal (covered in Chapter 3 of this document)
- 'Quality Assurance' of the LNG Carrier and the LNG Carrier Operator (covered in Chapter 4 of this document)

The process includes the following tasks:

- Check of the physical characteristics of LNG Carrier against the Terminal's requirements ("**Compatibility Study Process**")
- Assessment of the capability of the LNG Carrier to perform to predefined safety and environmental standards

Only those LNG Carriers which have successfully gone through both of these streams of the Approval Process will be approved by OLT to deliver LNG to the Terminal.

Note: the LNG Carrier's performance ("**Vessel Performance**") is monitored by OLT to ensure that the required performance levels are met and maintained.

The procedures established by OLT are broadly consistent with:

- existing international and national rules and regulations, implemented by the flag state / port state of the Terminal
- industry forum recommendations such as OCIMF (as published at <http://www.ocimf.com>), SIGGTO (as published at <http://sigtto.re-invent.net/DNN/>), GIIGNL (as published at <http://www.giignl.org/>) or Gas Infrastructure Europe (as published at <http://www.gie.eu.com>).

These LNG Carrier Approval & Vetting Procedures also address the following specific aspects:

- safety and security at the berth
- LNG Carrier verification prior to berth
- particulars of the LNG cargo and LNG Carrier during unloading operations

- crew qualifications
- the Terminal's safety and operational procedures

References:

[Chapter 3, "Compatibility Approval Steps"](#)
[Chapter 4, "Quality Approval Process"](#)

2.2 STRUCTURE OF THE APPROVAL PROCESS

Introduction

Each LNG Carrier proposed for unloading at the Terminal undergoes the Compatibility Study Process. This comprises an assessment of the LNG Carrier plus an assessment of the LNG Carrier's Operator. The process steps are listed in the following table.

Task	Action
1	Exchange preparatory information.
2	Compatibility Checklist.
3	Final Safety Inspection of LNG Carrier.
4	Unloading Test and Compatibility Approval.
5	LNG Carrier Compatibility Approval follow-up.

3.0 Compatibility Approval Steps

OVERVIEW

Introduction

This chapter provides detail on the steps used to approve compatibility

In this chapter

This chapter contains the following information:

3.1 Step 1 –Preparatory Information

3.2 Step 2 –LNG Carrier/Terminal Compatibility Study Checklist

3.3 Step 3 –LNG Carrier Final Safety Inspections

3.4 Step 4 –Unloading Test and LNG Carrier Compatibility Approval

3.5 Step 5 –LNG Carrier Compatibility Approval Follow-Up

3.1 STEP 1 –PREPARATORY INFORMATION

Objective	The main objective of Step 1 is to gather all necessary material (for example, information, data, drawings) to conduct the LNG Carrier / Terminal compatibility study (Compatibility Study)
Documentation exchange	<p>Exchange of information between OLT and the User is to be made through designated representatives of both parties. The User is to nominate its representative following first contact.</p> <p>Communication and documentation transmission means are to be email and/or fax. Alternative means to be agreed between parties if necessary.</p>
Information submitted by OLT	When OLT receives a request by the User's designated representative to deliver LNG at the Terminal from a LNG Carrier not already entered on the 'FSRU Toscana Acceptable LNG Carrier/Terminal Compatibility List' (as published on the OLT commercial web-site), the Terminal shall make available the documents described in the following table to the User.

Document	Description
Society of International Gas Terminal Operators (SIGTTO) 'Ship/Shore Questionnaire for Compatibility of Liquefied Gas Ships with Loading/Unloading Jetties'	This document provides details on mooring and manifold arrangements, loading arm, and other Terminal aspects required to conduct a Compatibility Study
Terminal Regulations and Information Booklet	This document includes information and procedures pertaining to safety and operational requirements at the Terminal that are necessary to, for example, fill out the International Maritime Organization (IMO) checklist at the Unloading Port
Cargo Handling Manual	This document describes the procedures for cargo handling
Environmental, Safety and Quality Minimum Criteria for LNG Carrier calling at GNL FSRU Toscana Terminal	This document provides an understanding of the minimum criteria with respect to the marine, environmental, safety and quality assurance standards
LNG and Gas Measurement Manual	This document provides information and procedures pertaining to LNG and gas measurement/sampling
Confirmation List of Terminal and LNG Carrier Operator for the performance of Compatibility Study	This document is divided in two sections: LNG Carrier and Terminal specification, necessary for the performance of Compatibility Study

Note: Users must retrieve port information related to marine aspects for access and berthing at the Terminal directly from the Maritime Authority of the Port of Livorno (Italy).

Information submitted by User Listed below is the information that the User must send to OLT before the Compatibility Study is performed as part of the approval process

Item	Description
LNG Carrier/Terminal Compatibility Plans	This document, if available, is to be provided as per SIGTTO information Paper #5, "Communication Necessary for Matching Ship to Berth". If it is not available, the User shall instead submit the following documents: <ul style="list-style-type: none"> • General Arrangement Plan • Manifold layout • Mooring arrangements • Drawing of the parallel body side of the LNG Carrier Reference: <i>SIGTTO Paper #5</i>
Confirmation List of Terminal and LNG Carrier Operator for the performance of Compatibility Study	The LNG Carrier specification and remarks sections of this document shall be fully completed in full by the User or the LNG Carrier Operator. The party completing these sections warrants the accuracy of the data provided.

Reference: Confirmation List attached

Information submitted by User, continued

Item	Description
SIGTTO Ship/Shore Questionnaire	The User or LNG Carrier Operator must submit a completed SIGTTO "Ship/Shore Questionnaire for Compatibility of Liquefied Gas Ships with Loading/Unloading Jetties".
LNG Carrier Questionnaire	SIGTTO form "Ship Information questionnaire for Gas Carrier" 1998, 2nd edition. Alternatively latest copy of OCIMF Vessel Particular Questionnaire (VPQ) may be required by the Terminal.
Certified Custody Transfer Measurement System description	Description of the LNG Carrier Custody Transfer Measurement System and certificate of accuracy for offshore use (1).
Tank Gauge Tables	User or LNG Carrier Operator shall provide approved copies
LNG Carrier Operational and Safety Procedures while Alongside	<p>Procedures pertaining to the International Safety Management (ISM) code which address:</p> <ul style="list-style-type: none"> • Mooring • Cargo transfer • Fire fighting <p>Complete the information for the LNG Carrier part necessary to complete the applicable checklist</p>
List of Survey Status	This is issued by the Classification Society for the LNG Carrier
Inspection Reports	<p>The User or the LNG Carrier Operator shall provide the latest copies of these inspection reports:</p> <ul style="list-style-type: none"> • Classification Society • SIRE vetting certificate • Port State Control (Paris MOU)
Certificate of Entry	The Certificate of Entry must be with a Protection & Indemnity (P&I) Club that is a member of the International Group of P&I clubs in the maximum amount available with the relevant P&I club (including coverage for the LNG Carrier's legal liabilities for damage to the Terminal, spills/pollution and other third party injury and property damage).
Departure Plan (Membrane Vessels)	<p>A safe condition departure plan in the event that the LNG Carrier is required to depart the Terminal prior to completion of cargo discharge reviewed/approved by Class or tanks manufacturer.</p> <p>Reference: <i>Terminal Regulations and Information Booklet</i></p>

(1) Users and LNG Carrier Operators must retrieve for themselves information related to the Maritime Authorities' approval for Custody Transfer Measurement System and Tank Gauge Tables.

3.2 STEP 2 – LNG CARRIER / TERMINAL COMPATIBILITY STUDY

Introduction

In order to verify both the technical compatibility of the LNG Carrier with the Terminal and the operational aspects, it is important that the LNG Carrier Operator, User, OLT and the Terminal Operator understand each other's operating procedures. This will be possible after reviewing all of the documents exchanged under Step 1.

Document analysis

After examining the information received in Step 1, OLT will perform, directly or via third party, a Compatibility Study to confirm whether the LNG Carrier is technically compatible with the Terminal. The conclusions from the Compatibility Study will be provided to the User or the User's designated representative and to the LNG Carrier Operator.

In particular, the Terminal will check the following minimum criteria:

- Physical and technical compatibility with the Terminal dimensions and specifications
- Nautical and safety aspects
- Compliance with Terminal communication links and ESD system
- Certification of gauge tables covering all cargo tanks in the LNG Carrier and Custody Transfer Measurement System

Note (1): Certification of gauge tables is verified by the relevant authorities and accepted by OLT before the first unloading. This certification must be carried out by an appropriately qualified organization

Note (2): Custody Transfer Measurement System specifications and methods must comply with the requirements and specifications detailed in Terminal Measurement Manual

Note: (3) Certification of gauge tables verified and accepted by relevant Maritime Authorities: LNG Carrier to use Ship's Agent services to deal with these requirements

Reference: *Terminal Measurement Manual*

Mooring arrangement

The LNG Carrier Operator shall prepare and present:

- a proposed mooring arrangement;
- a mooring calculation; and
- a drawing, for operational purposes only, of the proposed mooring arrangement for the specific LNG Carrier,

OLT will then review (directly or via a third party) the above received documentation and, if the LNG Carrier is compatible, shall issue, for operational purposes only, a drawing of the approved mooring arrangement for the specific LNG Carrier.

Continued

LNG CARRIER / TERMINAL COMPATIBILITY STUDY continued

Preliminary LNG Carrier / Terminal compatibility meeting

Following the completion of the document analysis, a preliminary LNG Carrier / Terminal compatibility meeting ("**Preliminary Meeting**") may be called at OLT's Livorno offices. This is attended by representatives of the LNG Carrier's Operator, Users and the Terminal Representative, in order to examine the berth, 'ship-shore' interfaces, safety and communications items in relation to the LNG Carrier and the Terminal.

The minimum agenda of the Preliminary Meeting is:

- review of Compatibility Study conclusions.
- review of all parameters of the LNG Carrier / Terminal safety plan completion. This will include the documents dealing with safety and security, such as fire fighting, cargo transfer, and mooring. All this will be checked and, if necessary, adapted.
- cargo tank custody transfer management.
- agent assignment and tasks.

Any LNG Carrier that successfully completes Steps 1 and 2 is considered a "**Compatibility Pre-approved**" * LNG Carrier for its initial voyage to the Terminal, subject to a successful Final Safety Inspection.

References:

- Appendix A, "Topics for Preliminary Meetings" for an informative list of topics to address during the Preliminary meeting.
- Chapter 4, "Quality Approval Process"

***SPECIAL CARGO CONDITION WHEN A LNGC CAN NOT COMPLY WITH MAX ADMISSIBLE MANIFOLDS ELEVATION DEPARTURE BALLAST CONDITION REQUESTED BY TERMINAL**

In case a vessel manifold elevation at ballast draft cannot comply with terminal max acceptance requirement of at least 22.7m, special conditions can be evaluated by terminal in order to accept the relevant vessel.

In particular the vessel concerned shall retain more heel on board in order to increase the draft and lower the manifold elevation, as explained below and provided that the following special acceptance conditions are accepted, confirmed and fulfilled by the vessel owner and/or operator on behalf of terminal user concerned.

In order to lower manifold elevation at departure ballast condition, vessel shall retain more heel on board. Considering the max cargo that vessel can retain onboard, the retained heel shall fall within the vessel's low operative sloshing limit.

The calculation to verify the fulfilment of the vessel manifold elevation shall be done under the following cumulative conditions:

- (i) the minimum consumable that vessel can retain on board as per trim and stability booklet or company procedure (water, gasoil, full oil etc...);
- (ii) the lightest LNG to be discharged which is admitted to the Terminal as per Terminal manual;
- (iii) max trim 1m;
- (iv) max heel considering low sloshing limit.

With regards to the above-conditions, please note that the following mandatory rules shall apply:

- Quantity of heel to retain on board shall be at any time no less of the quantity declared in the calculation expressed in liquid cubic meter.

- The actual consumable on board shall be immaterial for the calculation; calculation shall always consider the minimum permitted quantity of consumables on board in accordance to a most-conservative approach; as consequence the actual quantity of consumable on the vessel shall never be considered..

- The vessel owner, operator of the LNGC and Terminal user concerned accept all risks at their own cumulative responsibility in case the ship concerned, once moored, does not respect the manifold elevation limits and, in particular, it shall also be responsible to verify the calculation made by the Terminal in order to ensure that the elevation limit requirement is actually fulfilled by the vessel.

- The Terminal saves the right to check the required conditions from time to time also through vessel inspection (possibly once the vessel is nominated for discharge compatibility may be re-checked at any time).vessel owner provided to terminal the hydrostatic tables with specific references to TPC (Tonnage per centimeters table)

- The Terminal also reserves the possibility to stop loading operation and unberth the vessel every time it is reasonably convinced that the conditions of the draft are not respected or that there is any possibility that they are not met by the end of discharge.

Under the above conditions a vessel can fulfil the manifold elevation requirement, remaining however understood that:

- (i) The Terminal shall always be entitled to refuse the ship concerned if, at its sole and undisputable discretion, it deems that there is any risk associated to the vessel discharge operation, regardless of the calculation performed showing that the manifold elevation requirement is met.

- (ii) It is an obligation of the shipowner/operator to inform the Terminal user that the vessel is declared pre-accepted under such special conditions.

- (iii) during the compatibility process a declaration can be requested by the Terminal to confirm acceptances and fulfilment of such special conditions.

- (iv) It is responsibility of Terminal user as well as of the shipowner/operator calling at the Terminal to ensure that every time the ship is chosen to discharge at the OLT Terminal all the above conditions are permanently fulfilled by the vessel concerned over the entire mooring and unmooring procedure. Vessel owner, operator and user concerned remain all cumulatively responsible for the accuracy, correctness and completeness of the data used by the Terminal operator for the calculation.

Based on the above, once accepted, the vessel concerned will be declared pre-accepted under special Cargo conditions and it will be listed in the pre-accepted vessels list under a separate and dedicated sheet showing the conditions to be met by the same vessel for terminal acceptance. The publication of such information does not exempt the vessel owner or operator to inform the terminal user concerned about the actual acceptance conditions.

3.3 STEP 3 –LNG CARRIER SAFETY INSPECTION

Introduction

OLT requires the LNG Carrier to undergo a “**Final Acceptance Visit**” prior to berthing. This inspection is performed by the Terminal Representative and/or by a Third Party and is done according to the inspection guidelines established by OLT.

These inspection guidelines are consistent with the Oil Companies International Marine Forum (OCIMF) inspection guidelines and SIGTTO’s latest recommendations for crew safety standards and training on LNG Carriers.

The following table describes the Final Acceptance Visit process.

Step	Responsible	Action
1	Terminal Representative	<p>The Terminal Representative may find the LNG Carrier either “acceptable” or “unacceptable” for berthing or unloading at the Terminal. The Terminal Representative will as soon as practical advise the LNG Carrier Master, User, the Maritime Authority, the Pilot, OLT, the Terminal Operator and the ship’s agent accordingly.</p> <p>In case the LNG Carrier is found unacceptable the Terminal Representative will issue a “Rejected Report” which will include a list of remarks and deficiencies found.</p> <p>Reference : Terminal Regulations 11.1</p>
2	OLT	Sends the Rejected Report including the list of remarks and deficiencies to the User.
3	User	Forwards them to the LNG Carrier Operator and/or the charterer.
4	User	Provides plan for implementation of corrective actions to OLT.
5	OLT	Upon receipt and review of the plan for the implementation of corrective actions and confirmation that the plan has been fully carried out, OLT will decide whether to perform a second inspection in order to receive the LNG Carrier at the Terminal.
6	User	Promptly notifies or procures that OLT is notified if any LNG Carrier that is owned, chartered or otherwise employed by the User, pre-approved or approved, has been rejected or has failed a ship safety inspection at another LNG terminal.
7	User	Provides OLT with all relevant technical details and information in relation to that rejection or failure of safety inspection.

3.4 STEP 4 –UNLOADING TEST AND LNG CARRIER COMPATIBILITY APPROVAL

Introduction

Depending on the outcome of the previous steps, an LNG Carrier will be deemed either technically approved for a single cargo unloading, subject to successful voyage screening (see Chapter 4) which includes the “**Unloading Test**” described below, or be rejected.

Reference: Chapter 4, "Quality Approval Process"

Unloading Test

If the LNG Carrier is approved pursuant to steps 1, 2 and 3, a single cargo unloading is permitted.

The LNG Carrier Unloading Test will determine whether the LNG Carrier crew understands the Terminal interface and will establish LNG Carrier/ Terminal compatibility. The Test will be assessed by the Terminal Representative.

Before unloading the LNG cargo, a pre-discharge meeting is held on-board LNG Carrier. During this meeting, the following will occur:

- A review of the Terminal Regulations and Information Booklet in order to ensure the crew’s understanding of the Terminal requirements, including, but not limited to:
 - Mooring, piloting, manoeuvring and towing;
 - Weather policy;
 - Fire fighting;
 - Unloading arm connection, disconnection and working envelope;
 - Cargo transfer, including discharge rates and minimum pressure to be maintained at Terminal’s loading headers during discharge; and
 - Cargo tank management;
 - Unloading communication; and
 - Emergency/Contingency procedures
 - A discussion of operational procedures (Note: certification of gauge tables is verified and accepted by the relevant authorities before the first unloading. This certification must be issued by a Qualified Organization.)
 - A copy of the the Terminal Regulations and Information Booklet will be delivered to the LNG Carrier's Master by the Terminal Representative.
 - The LNG Carrier's Master and the Terminal Representative will check and sign the "IMO International Ship/Terminal safety checklist and guidelines"
-

Continued

Unloading Test and LNG Carrier compatibility approval, continued

LNG Carrier compatibility approval procedure conclusion

Depending on the findings of the Unloading Test Report, OLT will determine if an LNG Carrier is technically compatible and suitable for future unloading at the Terminal. OLT will advise if the LNG Carrier:

- is approved for a thirty-six (36) month approval period, without being subjected to further Unloading Tests; or
- is accepted in future for another Unloading Test pending implementation of corrective action to the LNG Carrier; or
- is not accepted in future (without prior completion of the full Approval Procedure).

Any approval or condition is based upon the LNG Carrier's state at the time of the approval or condition definition. In case of change in the commercial, technical capabilities or specification of the LNG Carrier, OLT shall be notified of the change as soon as is practicable. Based on OLT's assessment of the change, it is in OLT's sole discretion to review its prior approval or condition.

Where the LNG Carrier is approved, as above, it will subsequently be entered in the list ('FSRU Toscana Acceptable LNG Carrier/Terminal Compatibility List') which is published on the OLT commercial web-site.

Note: As a good practice terminal will recheck if compatibility conditions have been maintained before each call.

At the expiration 36 months approval period, unless the owner re-checks the compatibility, the vessel will be suspended from the list of pre-accepted or compatible vessel.

3.5 STEP 5 –LNG CARRIER COMPATIBILITY APPROVAL FOLLOW-UP

Introduction

Before and during each call at the Terminal, the User must provide timely assistance to OLT, to clarify and solve any urgent issues that arise before or during each call of one of User's LNG Carriers.

The User must keep OLT informed of any modifications to the LNG Carrier, or any changes in its condition or maintenance status related to technical, safety and/or managerial issues that may affect or have an impact upon prior approval of the LNG Carrier in question. Upon notification of such modifications or changes, OLT will assess if the prior approval of the LNG Carrier in question needs to be reconsidered.

OLT may require additional safety and technical inspections, in order to check the continued compliance of the LNG Carrier with safety and operational requirements of the Terminal. These inspections, at OLT's discretion, may occur prior to the time of berthing or at any other time and place determined by OLT, always in compliance with the Access Code.

Reference: Section 5.4, "Terminal Feedback Reports"

4.0 Quality Approval Process

OVERVIEW

Introduction

This chapter provides the process for quality approval of LNG Carriers nominated to call at the Terminal.

In this chapter

This chapter contains the following information:

4.1 Quality Vetting Requirements

4.2 Rejected LNG Carriers

4.3 The Elements of Quality Vetting

4.1 QUALITY VETTING REQUIREMENTS

Introduction

OLT requires that all LNG Carriers, prior to calling at the Terminal, have a quality vetting approval within the six months before the date of the LNG Carrier's proposed first call at the Terminal. The User is responsible for coordinating at its sole risk and expense the inspection of the LNG Carrier consistent with the quality vetting approval requirements (i) prior to the LNG Carrier's first call at the Terminal and (ii) prior to the LNG Carrier's first call at the Terminal following any material modification to such LNG Carrier and/or the Terminal.

OLT may require an additional inspection of any LNG Carrier nominated by the User if OLT determines that such inspection is necessary to ascertain such LNG Carrier's compliance with OLT's quality requirements.

Such additional inspection may be carried out directly by OLT's representatives or by a 'Quality Assurance' organization appointed by OLT.

The User must advise OLT in a timely manner of the cargo loading dates so that the inspection may be carried out prior to the loading of the LNG Carrier. OLT will notify the LNG Carrier Operator/User of the identity of the 'Quality Assurance' organization appointed.

Quality Vetting Pre - approval

OLT or the 'Quality Assurance' organization will inspect and review the LNG Carrier nominated to call at the FSRU Toscana Terminal for the 'Quality Assurance' of the LNG Carrier and the LNG Carrier Operator. If found acceptable, the LNG Carrier is pre-qualified by OLT to call at the Terminal.

Full acceptance for technical compatibility is not met until the LNG Carrier has successfully completed the compatibility approval steps, final inspection and Unloading Test.

Approval to call at the Terminal may be rescinded at OLT's discretion if, whilst the LNG Carrier is on passage, OLT receives adverse information that may affect OLT's prior approval of the LNG Carrier.

Not approved LNG Carriers

LNG Carriers assessed via the OLT screening process as "**Not Approved**" in the base case are not accepted for delivery of cargo to the Terminal and OLT will require that the User nominates an alternative LNG Carrier.

Note: it is advised that LNG Carrier nominations are made with sufficient lead time to allow for the potential need to find an alternate LNG Carrier.

Pre-approval period

OLT requires that Users must demonstrate that they have access to acceptable LNG Carriers to call at the Terminal. The quality pre-qualified period is for 12 months.

4.2 REJECTED LNG CARRIERS

General

LNG Carriers that fail to pass the Quality Vetting Requirements (ref. Chapter 4.1) are assessed as *Not Approved*.

Reference: Section 4.3, "The Elements of Quality Vetting"

OLT will communicate the rejection decision.

LNG Carriers assessed via the vetting/quality process as "Not Approved" in the base case are not accepted for delivery of cargo to the terminal and OLT requires that the User proposes an alternative LNG Carrier before cargo loading and/or in time enough to allow for completion of the approval process.

LNG Carrier on "doubts"

If an LNG Carrier is placed on "*doubts*" it means that conditions that potentially affect its performance have been identified.

These may be identified during the SIRE inspection evaluation, as a result of a Vessel Performance Report from other re-gasification terminals, or originate from some other source. The LNG Carrier Operator is informed by OLT of any *doubts* which remain in place until OLT receives a satisfactory response by the User.

In cases where there is no response to the *doubts* highlighted, if the *doubts* are deemed significant, OLT considers that the LNG Carrier is *Not Approved* until the *doubts* have been cleared. This normally requires some discussion or documented evidence between the User and OLT. If, however, the *doubts* are minor, OLT may evaluate and recommend the LNG Carrier as "*Approved-Subject to...xxx..*" with the *doubts* to be cleared before calling at the Terminal or by a later date.

Such *doubts* may also arise even where there are no actual deficiencies with the LNG Carrier. OLT may recommend that the LNG Carrier Operator complies with certain guidelines or regulations, or takes special precautions for a particular set of circumstances arising from the intended use of the LNG Carrier.

LNG Carrier "on hold"

Any LNG Carrier may be placed *on hold* for a number of technical or operational reasons. As a consequence, an LNG Carrier is designated *Not Approved* to call at the Terminal until the reasons for the *hold* are adequately addressed.

The reasons an LNG Carrier may be placed *on hold* include, but are not limited to, the following:

- The LNG Carrier is involved or has been involved in a pollution, collision, fire/explosion, or grounding or similar type incident.
- The LNG Carrier is judged to present an unacceptable safety and/or environmental risk.
- The LNG Carrier Operator's performance/policies are judged to present an unacceptable safety and/or environmental risk.

OLT shall not be liable for any cost, loss or expense incurred by the User for the *on hold* decision.

4.3 THE ELEMENTS OF QUALITY VETTING

Elements

In vetting the LNG Carrier, OLT or the 'Quality Assurance' organization (as approved by OLT) will use a variety of data such as:

- The most recent SIRE Vessel Inspection Questionnaire (VIQ)
- Previous LNG Carrier inspection history
- LNG Carrier history
- Prior performance at the Terminal
- Prior performance at other re-gasification terminals, if available
- Outstanding technical issues on the LNG Carrier
- Classification Society records relating to the LNG Carrier
- Port State Inspection records
- Assessment of the LNG Carrier Operator's TMSA including audit findings
- Structural reviews
- Casualty / incidents
- Industry intelligence
- Compliance with *Environmental Safety and Quality Criteria* (ESQC)

ESQC

The ESQC booklet prepared by OLT is available to all LNG Carrier Operators. The primary purpose of the document is to outline the Safety and Environmental and Quality Criteria required supplemental to those provided by Statutory Regulations.

In addition, it covers areas such as compliance with the Drug and Alcohol policy, 'Quality Assurance' organization inspection process and incident reporting.

LNG Carrier Operators must acknowledge and familiarize themselves with the ESQC that is part of the manuals delivered to Users / LNG Carrier Operators.

TMSA

As part of the vetting analysis, OLT or 'Quality Assurance' organization (approved by OLT) will evaluate the TMSA submission made by the LNG Carrier Operator.

All LNG Carrier Operators with LNG Carriers nominated to call at the Terminal must submit a TMSA report to OCIMF and release it to OLT or to the 'Quality Assurance' organization. This report is valid for twelve (12) months, but may be updated at anytime during this period.

OLT or the 'Quality Assurance' organization will maintain a rating for all LNG Carrier Operators. This rating is based on LNG Carrier Operator performance supplemented with an analysis of TMSA reports, as well as any audits of the LNG Carrier Operator's safety management system.

Reference: *OCIMF Tanker Management Self Assessment Program (TMSA)*

5.0 Ship Inspection Report Program (SIRE) Inspections

OVERVIEW

Introduction

This chapter provides an overview of the inspection process, feedback reports and incident reporting requirements

In this chapter

This chapter contains the following information:

5.1 Overview of SIRE and Application to Terminal

5.2 SIRE Inspections

5.3 Incident Reporting

5.4 Terminal Feedback Reports

5.1 OVERVIEW OF SIRE AND APPLICATION TO TERMINAL

Introduction

SIGTTO recommends that the SIRE inspection process is used for quality inspections of LNG Carriers

SIRE is an established, nonprofit, proven system, based on the marine expertise and experience of OCIMF members. More information are available at:
http://www.ocimf.com/tree_browse.cfmaction=sire_programme.

The VIQ is a continuously improved document that provides a structured and factual reporting process.

SIRE inspectors are accredited to ensure that they have an appropriate level of experience and qualification.

Reference: *SIGTTO, Ship Vetting and its Application to LNG*

5.2 SIRE INSPECTIONS

SIRE Inspection

The LNG Carrier Operator ensures that an operational VIQ for the LNG Carrier is available. The LNG Carrier Operator is responsible for arranging an operational inspection at least every 6 months. The LNG Carrier Operator must promptly submit any responses relating to observations raised during the inspection to the VIQ. This enables the comments to be considered during any subsequent LNG Carrier vetting.

Reference: VIQ

5.3 INCIDENT REPORTING

Requirements

In line with TMSA guidance, LNG Carrier owners and LNG Carrier Operators must maintain an internal incident and near-miss reporting and recording system. Using this system, they can record "lessons learned" and take necessary preventative actions.

The LNG Carrier Operator must as soon as practical inform OLT (lngc@oltoffshore.it) and/or the 'Quality Assurance' organization (approved by OLT) of any incidents or accidents sustained by or on the LNG Carrier. The reporting requirement is for all activities that the LNG Carrier undertakes (not just those activities that are exclusive to the Terminal).

OLT and/or the 'Quality Assurance' organization will evaluate such information as part of the vetting/quality requirements.

All incidents reported to OLT and/or the 'Quality Assurance' organization by the LNG Carrier Operator, or obtained through media/other industry sources will be recorded.

LNG Carrier Operators must undertake their own internal investigation to determine prime and root causes of the incident, and take corrective action to prevent recurrence. Investigation results to be made available to OLT on request.

Following an incident (wherever it takes place), the LNG Carrier, at OLT's discretion, may be placed *on hold* (for example, but not limited to, the LNG Carrier may be prevented from berthing at the Terminal) until OLT reviews the incident report and makes a determination that the LNG Carrier remains accepted. OLT shall not be liable for any cost, loss or expense incurred by the User, the LNG Carrier Operator or the LNG Carrier for such *on hold* decision.

5.4 TERMINAL FEEDBACK REPORTS

Feedback Report

For all LNG Carrier calls at the Terminal, the Terminal will complete a Terminal Feedback Form.

The Terminal Representative completes this form during the post transfer conference and advises the LNG Carrier Master of any issues arising from the LNG Carrier's call at the Terminal. These issues will be included in a report provided to the User by OLT.

Reference: Section 3.5, "Step 5 - LNG Carrier Compatibility Approval Follow-Up"

The report is one of the elements considered by OLT during the vetting/quality analysis for an LNG Carrier nominated to call at the Terminal. Use of the report will be limited to OLT and will not be shared with third parties.

In cases of a negative feedback reports, or where OLT indicates that the LNG Carrier's performance is unacceptable, the LNG Carrier Operator shall be notified and provided with details of actions needed to be taken by the LNG Carrier Operator to rectify the identified issues.

OLT may place the LNG Carrier on hold until the concerns have been adequately addressed by the LNG Carrier Operator and reviewed by OLT / 'Quality Assurance' organization (approved by OLT). OLT shall not be liable for any cost, loss or expense incurred by the User, the LNG Carrier Operator or the LNG Carrier for such *on hold* decision.

6.0 LNG Carrier / Terminal Compatibility

OVERVIEW

Introduction

This chapter provides Terminal-specific requirements additional to the standard compatibility requirements for LNG Carriers calling at the Terminal.

In this chapter

This chapter contains the following information:

6.1 Specific LNG Carrier Requirements for the Terminal

6.1 SPECIFIC LNG CARRIER REQUIREMENTS FOR THE TERMINAL

Requirements

There are specific requirements that apply to every LNG Carrier that calls at the Terminal.

OLT includes these requirements as part of the LNG Carrier / Terminal Compatibility Study Process and OLT acceptance. The requirements are:

- LNG Carrier must be in compliance with International Standards which means the standards and practices (guidelines) from time to time in force and applicable to the ownership, design, equipment, operation or maintenance of LNG carriers established by the rules of the IACS Classification Society or such other Classification Society that may be acceptable to OLT (in its sole discretion), the conventions, rules, guidelines and regulations laid down by the International Maritime Organization (IMO), the Oil Companies International Marine Forum (OCIMF), International Group of Liquefied Natural Gas Importers (GIIGNL), Society of International Gas Tankers and Terminal Operators (SIGTTO) (or any successor body of the same) and any other internationally recognized agency or organization with whose standards and practices it is customary for international operators of such vessels or terminals to comply, including the holding of a valid operational OCIMF Ship Inspection Reporting system (SIRE) certificate
- Minimum requirement for LNG Carrier's manifold shall be the compliance with OCIMF "Recommendation for manifold for refrigerated liquefied natural gas carriers (LNG)", second edition 1994 for all parameters (including spillage requirements, loads, spacing, material, mesh, etc).
- LNG Carrier to be in compliance with SIGTTO ESD arrangements (Optic+Pyle National or Pneumatic as back up) "SIGTTO ESD Systems and Linked Ship Shore Systems, edition 2009".
- LNG Carrier to be equipped with a port side manifold crane adequate to lift offshore n° 4 FMC spool pieces package cone and box = 800 KG SWL static each.
- LNG Carrier shall be responsible (and liable) for loading on board and fitting the target/cone distance piece on the presentation flange under the Terminal Berthing Master's supervision.
- LNG Carrier shall be able to maintain during all discharge, regardless of the discharging rate, a minimum pressure of 1,8 Barg at Terminal loading headers.
- LNG Carrier's mooring arrangement to be in compliance with OCIMF "Mooring Equipment Guidelines" latest edition.
- LNG Carrier's port parallel body side to allow contact with 5 fenders at 100%.
- LNG Carrier to confirm the compatibility with offshore environmental requirements of the proposed mooring equipment (winch, fair lead, chock, etc).
- LNG Carrier to be equipped in order to present 16 mooring lines, including 4 aft springs.

Head, stern, spring and breast mooring lines must be fitted with 22-meter eight (8) strand synthetic mooring tails or any other suitable length as decided during the Compatibility Study Process. Certificates and inspection data in respect of these lines must be made available to OLT on request. All mooring line and tails to be single leg type and NO Grommet. All tails must be of same material and similar TDBF (MBL). 11m tails are not acceptable.

- Wire mooring ropes with shackle link for tails are accepted; HMPE mooring ropes with cow link on tails are preferred. Shackle SWL to be in compliance with latest MEG recommendation.
- LNG Carrier to evaluate during the Compatibility Study Process the needs of protecting the vessel mooring lines from abrasion with its hull, fairleads and chocks

- 'Departure Plan' (including partial fill operation for membrane tank type LNG Carriers)
 - **Reference:** *Terminal Regulations and Information Booklet*
- LNG Carrier must be fitted with 60 mesh manifold loading strainers, as per SIGTTO "Recommendations for the Installation of Cargo Strainers on LNG Carriers", 2nd Edition 1992.
- If vessel is doing her first discharge after drydock, needs to install 200 mesh strainer. At end of operation filters to be inspected and any eventual residues to be sampled and analyzed by cargo surveyor.
- LNG Carrier to have full collapsible or removable handrails from Liquid 1 to Liquid 4 manifolds, to allow use of the Loading Arm cable connection guidance system. It is necessary to have a clearance not less than 1 m fwd of liquid manifold N1 center.
- LNG Carrier's air emissions to be in accordance with European Union Directive 2005/33/EC (D.Lgs 6/11/2007, n. 205)
- LNG Carrier older than 30 years will not be accepted
- For mooring lay out required and acceptable by terminal please ref to confirmation list Sheet 1, 2, 3.
- For lngc bits, panama swl and position please ref to confirmation list "Tug Position".

In case any LNG Carrier calling at the Terminal does not comply with the International Standards as stated above and the other, Terminal-specific, criteria set out above. that LNG Carrier will be subject to a "**Non-standard Compatibility Study Process**". This will be specifically tailored for each LNG Carrier and may include, for guidance only, a dedicated study of the unloading arms connection, mooring analysis, hydrodynamics etc.

Time to perform such Non-Standard Compatibility Study Process to be evaluated on case-by-case basis. All costs in performing said Non-Standard Compatibility Study Process to be for the User's account.

SPECIAL PROVISION

When entering within eight miles distant from the Terminal, propulsion and energy generation on board LNG Carrier must use only Boil Off Gas as fuel; this is applicable both when navigating and when alongside the Terminal. Exceptions are possible only for safety, emergency, technical functionality of LNG Carrier equipment and / or with specific authorization from the Maritime Authorities.

Reference: SIGTTO "Recommendations for the Installation of Cargo Strainers on LNG Carriers", 2nd Edition 1992

A. Topics for Preliminary Meetings

Introduction

This appendix provides a minimum list of discussion topics for a preliminary meeting.

Topic	Description
Parties' representatives and contact details	The Terminal Representative and the User's representatives must be identified before the meeting and their contact details made available.
'LNG Custody Transfer' checklist	<p>Items to address for this topic are (but not limited to):</p> <ul style="list-style-type: none"> • SIGTTO/OCIMF compatibility table discussion • Buyer/Seller obligations and rights • Risk Coverage (insurance) • Standards and units of measure • LNG quality specification (compatibility with pipeline gas quality limitations) • Wobbe index • HHV (Higher Heating Value) • Nitrogen content (less than 1,2 mol%) • Contaminants • Sulphur and mercury compounds • Impurities • Quality determination method • Boil-off gas handling • LNG measurement • Actions under deviation
LNG Carrier	<p>Items to address for this topic are the LNG Carrier's:</p> <ul style="list-style-type: none"> • General arrangement of ship's deck, clearly indicating mooring winches, bollards, hull penetration, and so on; • Permanent communication channels onboard, for example: <ul style="list-style-type: none"> - (Inmarsat) telephone numbers - Fax numbers and email addresses - Exact geometric volume of each cargo tank necessary for custody transfer calculations - LNG Terminal (information for the LNG Carrier) including maximum dimensions of LNG Carrier
Port user/operator	<p>Items to address for this topic are:</p> <ul style="list-style-type: none"> • Authority, contact person(s) • Ship's agent • LNG Carrier requests for additional services • Procedures for arranging of Pilots • Tugs

Continued

Topics for Preliminary Meetings, continued

Topic	Description
Pilotage / berth approach	Items to address for this topic are: <ul style="list-style-type: none"> • Communications • Pilot boarding • Number of tugs • Mooring arrangement and procedures
LNG Carrier / Terminal safety interface	This topic concerns emergency procedures and operational interfaces: <ul style="list-style-type: none"> • Contingency planning with a representative of the LNG Carrier Operator • Communications • Emergency response communications and liaison, including Public Affairs response
Mechanical Interfaces	Items to address for this topic are: <ul style="list-style-type: none"> • Unloading arm arrangements and operating envelope, including: <ul style="list-style-type: none"> ○ flange location, standard and size ○ Mesh requirements ○ cable guided system
Instrumentation Interfaces	Discuss the location and connector specifications for the umbilical communication systems (for example, Pyle National connector and /or pneumatic ESD and /or optical connector) for ESD systems
Ship/Terminal safety checklist	Check and confirm: <ul style="list-style-type: none"> • Safety interfaces • Procedures • Equipment • Safety tests (for example, the ESD test before start of unloading operation) • Crisis management plan
Cargo transfer arrangements	Discuss cargo transfer arrangements: <ul style="list-style-type: none"> • Offloading rates and pressure at Terminal loading headers • Cool-down • Vapour return procedures
Other information	Any other relevant information that exists at the time of the meeting

Glossary

Terms, abbreviations and acronyms

The following terms, abbreviations, and acronyms are used throughout this document

Terms	Description
ESQC	Environmental Safety and Quality Criteria
FSRU Toscana	Floating Storage and Regasification Unit – IMO no. 9253284 – Flag Italian LI 10153
LNG Carrier	The term LNG Carrier is used throughout this document to mean a liquefied natural gas carrier intended to call at the Terminal
LNG Carrier Operator	The operator responsible for the technical operation and manning of the LNG Carrier, as defined in the Terminal Regulations.
Maritime Authorities	Means the Ministry of Infrastructures and Transport (Ministero delle Infrastrutture e dei Trasporti), the Autorità Portuale (Port Authority) and the Harbour Master.
Master	Any person legally and duly certified and appointed as commanding officer responsible for the navigation and management of an LNG Carrier or in his absence his duly authorized deputy
OCIMF	Oil Companies International Marine Forum
OLT	Off Shore LNG Toscana S.p.A. – owner and commercial operating company of the Terminal
SIGTTO	Society of International Gas Tanker and Terminal Operators
SIRE	The OCIMF Ship Inspection and Reporting system
Terminal	FSRU Toscana, including berth area and other facilities within the two nautical miles exclusion zone and Terminal management designated by OLT. Such management includes the person or persons (and his/their deputies and assistants) authorized by OLT to exercise the powers or perform the duties related to making and enforcing regulations, administration and control of the plant and berths.
Terminal Operator	The company appointed and authorized by OLT to perform the management and technical operation of the Terminal in accordance with ISM Code and ISO 9001 and 14001.
Terminal Regulations	The Terminal Regulations and Information Booklet as updated from time to time by OLT, which apply to LNG Carriers and Users in connection with the operation of LNG Carriers at the Terminal.
Terminal Representative	The designated person (s) who will board the LNG Carrier on behalf of the Terminal and will act as coordinator between the Terminal and LNG Carrier. The Terminal Representative or 'Berthing Loading Master' is in direct communication with the Terminal control room.
TMSA	Tanker Management Self-Assessment program
User	Any person to whom OLT provides the Services pursuant to a Capacity

	Agreement
VIQ	SIRE Vessel Inspection Questionnaire

CONFIRMATION LIST OF LNG CARRIER OPERATOR FOR THE PERFORMANCE OF COMPATIBILITY STUDY

(as example)

LNG Carrier Approval & Vetting Procedures

OLT Offshore LNG Toscana SpA - FSRU TOSCANA @ LIVORNO Compatibility Template to be filled by LNGC Owner/Operator in all parts. In accordance to chapter 2.2 of regasification code of the OLT terminal

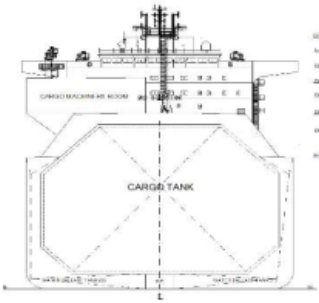
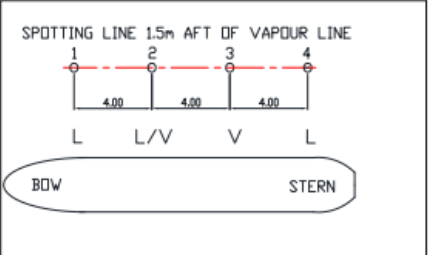
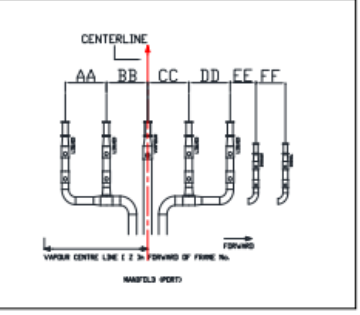
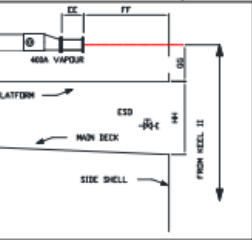
Items	Toscana-Shore Specification	Ship Specification	Remarks	Confirm Result
I. Max dimension 1. General	<p>Terminal Name: FSRU TOSCANA Latitude: 43° 38' 40"N Longitude: 09° 59' 20"E</p> <p>Country: Italy</p> <p>Terminal Description: Terminal is authorized to discharge vessel between 65k and 180k</p> <p>LOA: 306,49 m Breadth: 48,00 m Depth Moulded: 26,50 m Ballast draft: 10,76 m Load Draft: 12,30 m FSRU Capacity (98%): 134411 m</p>	<p>Ship's Name: IMO number: Nationality:</p> <p>Port of registry: Owner: Address: Builder: Address: Type of CCS:</p>	<p>Midship Section</p> 	
2. Max. Size of Vessel	<p>(1) Loa: 305,00 m (3) Max. Breadth: 54,00 m (5) Max. Draft: 12,00 m (6) Max. auth. capacity: 180000 m (7) Max. Displacement: 140.000 t</p> <p>Vessel side alongside: On FSRU STB SIDE, LNGC Port side alongside above parameters are maximum specifications of acceptable vessels and are subject to mooring lay out verification)</p>	<p>Ship Principal Dimensions</p> <p>(1) Loa: m (2) Lpp: m (3) Breadth (Moulded): m (4) Depth (Moulded): m (5) Draft (Design Load): m GM m (Summer): m GM m (Ballast): m GM m *(heavy ballast): m GM m</p> <p>(6) Air Draft: m (7) Displacement (Ballast): t *TRIM MAX 1m (Design): t (Summer): t (8) Deadweight (Design): t (Summer): t (9) Gross tonnage abt. (10) Net Tonnage abt. (11) Cargo carrying capacity abt. m3</p>		
II. Loading Arms / Manifold	<p>Loading Arm (Unit: mm)</p> 	<p>Insert manifold dimensions as per the sketch below (unit: mm)</p>  <p>AA: BB: CC: DD: HFO EE: MDO FF:</p> <p>Frame no = Z=</p>	<p>Insert Manifold dimension as per the sketch below:</p>  <p>EE: mm FF: mm GG: mm HH: mm II: mm</p> <p>Can the port side manifold loading platform hand rails be removed or lowered to deck level? This is required to allow the target wire to function properly. (necessary from 1m fwd of liquid 1 center to liquid 4) YES / NO</p> <p>LNGC MANIFOLDS shall comply with and meet all Manifolds' construction and strength requirements provided by SIGTTO manifold recommendations for liquefied gas carrier (ed. 2011) and in particular with paragraph 4.3 of the same or SIGTTO recommendation for liquefied Gas carrier manifold (second edition 2018) YES / NO</p>	

By performing this Ship-Shore Compatibility analysis the information provider authorizes OLT to pass all such information to the Terminal Operator and to any third party that needs, at OLT's sole and undisputable discretion, such information for the purpose of using (or evaluating its use) or to carry out their activity. In order to disclose such information to a third party OLT shall be exclusively subject to the obligation to procedure that the disclosed third party will not disclose the disclosed information to other third parties having no interest in using the FSRU.

LNG Carrier Approval & Vetting Procedures

OLT Offshore LNG Toscana SpA - FSRU TOSCANA @ LIVORNO Compatibility Template to be filled by LNGC Owner/Operator in all parts in accordance to chapter 2.2 of regasification code of the OLT terminal

Items	Toscana-Shore Specification	Ship Specification	Remarks	Confirm Result
I. Max dimension 1. General	<p>Terminal Name: FSRU TOSCANA Latitude: 43° 38' 40"N Longitude: 09° 59' 20"E</p> <p>Country: Italy</p> <p>Terminal Description: Terminal is authorized to discharge vessel between 65k and 180k</p> <p>LOA 306,49 m Breadth 48,00 m Depth Moulded 26,50 m Ballast draft 10,76 m Load Draft 12,30 m FSRU Capacity (98%) 134411 m</p>	<p>Ship's Name: IMO number: Nationality:</p> <p>Port of registry: Owner : Address: Builder: Address: Type of CCS:</p>	<p>Midship Section</p>	
2. Max. Size of Vessel	<p>(1) L_{oa}: 305,00 m (3) Max. Breadth: 54,00 m (5) Max. Draft: 12,00 m (6) Max. auth. capacity: 180000 m (7) Max. Displacement: 140.000 t</p> <p>Vessel side alongside: On FSRU STB SIDE, LNGC Port side alongside</p> <p>above parameters are maximum specifications of acceptable vessels and are subject to mooring lay out verification)</p>	<p>Ship Principal Dimensions</p> <p>(1) L_{oa}: m (2) L_{pp}: m (3) Breadth (Moulded): m (4) Depth (Moulded): m (5) Draft (Design Load): m GM m (Summer): m GM m (Ballast): m GM m (heavy ballast): m GM m</p> <p>(6) Air Draft: m (7) Displacement (Ballast): t *TRIM MAX 1m (Design): t (Summer): t (8) Deadweight (Design): t (Summer): t (9) Gross tonnage abt. (10) Net Tonnage abt. (11) Cargo carrying capacity abt. m3</p>		
II. Loading Arms / Manifold	<p>Loading Arm (Unit: mm)</p>	<p>Insert manifold dimensions as per the sketch below (unit : mm)</p> <p>AA: mm BB: mm CC: mm DD: mm EE: mm FF: mm</p> <p>HFO MDO</p> <p>Frame no = Z=</p>	<p>Insert Manifold dimension as per the sketch below:</p> <p>EE: mm FF: mm GG: mm HH: mm II: mm</p> <p>Can the port side manifold loading platform hand rails be removed or lowered to deck level? This is required to allow the target wire to function properly. (necessary from 1m fwd of liquid 1 center to liquid 4)</p> <p>YES / NO</p> <p>LNGC MANIFOLDS shall comply with and meet all Manifolds' construction and strength requirements provided by SIGTTO manifold recommendations for liquefied gas carrier (ed. 2011) and in particular with paragraph 4.3 of the same or SIGTTO recommendation for liquefied Gas carrier manifold (second edition 2018)</p> <p>YES / NO</p>	

By performing this Ship-Shore Compatibility analysis the information provider authorizes OLT to pass all such information to the Terminal Operator and to any third party that needs, at OLT's sole and undisputable discretion, such information for the purpose of using (or evaluating / to use) or to carry out their activity. In order to disclose such information to a third party OLT shall be exclusively subject to the obligation to procedure that the disclosed third party will not disclose the disclosed information to other third parties having no interest in using the FSRU.

LNG Carrier Approval & Vetting Procedures

SPECIAL CARGO CONDITION WHEN A LNGC CAN NOT COMPLY WITH MAX ADMISSIBLE MANIFOLDS ELEVATION DEPARTURE BALLAST CONDITION REQUESTED BY TERMINAL

In case a vessel manifold elevation at ballast draft cannot comply with terminal max acceptance requirement of at least 22.7m, special conditions can be evaluated by terminal in order to accept the relevant vessel. In particular the vessel concerned shall retain more heel on board in order to increase the draft and lower the manifold elevation, as explained below and provided that the following special acceptance conditions are accepted, confirmed and fulfilled by the vessel owner and/or operator on behalf of terminal user concerned.

In order to lower manifold elevation at departure ballast condition, vessel shall retain more heel on board. Considering the max cargo that vessel can retain onboard, the retained heel shall fall within the vessel's low operative sloshing limit.

The calculation to verify the fulfilment of the vessel manifold elevation shall be done under the following cumulative conditions:

- (i) the minimum consumable that vessel can retain on board as per trim and stability booklet or company procedure (water, gasoil, full oil etc...);
- (ii) the lightest LNG to be discharged which is admitted to the Terminal as per Terminal manual;
- (iii) max trim 1m;
- (iv) max heel considering low sloshing limit.

With regards to the above-conditions, please note that the following mandatory rules shall apply:

- Quantity of heel to retain on board shall be at any time no less of the quantity declared in the calculation expressed in liquid cubic meter.
- The actual consumable on board shall be immaterial for the calculation; calculation shall always consider the minimum permitted quantity of consumables on board in accordance to a most-conservative approach; as consequence the actual quantity of consumable on the vessel shall never be considered..
- The vessel owner, operator of the LNGC and Terminal user concerned accept all risks at their own cumulative responsibility in case the ship concerned, once moored, does not respect the manifold elevation limits and, in particular, it shall also be responsible to verify the calculation made by the Terminal in order to ensure that the elevation limit requirement is actually fulfilled by the vessel.
- The Terminal saves the right to check the required conditions from time to time also through vessel inspection (possibly once the vessel is nominated for discharge compatibility may be re-checked at any time).vessel owner provided to terminal the hydrostatic tables with specific references to TPC (Tonnage per centimeters table)
- The Terminal also reserves the possibility to stop loading operation and unberth the vessel every time it is reasonably convinced that the conditions of the draft are not respected or that there is any possibility that they are not met by the end of discharge.

Under the above conditions a vessel can fulfil the manifold elevation requirement, remaining however understood that:

- (i) The Terminal shall always be entitled to refuse the ship concerned if, at its sole and undisputable discretion, it deems that there is any risk associated to the vessel discharge operation, regardless of the calculation performed showing that the manifold elevation requirement is met.
- (ii) It is an obligation of the shipowner/operator to inform the Terminal user that the vessel is declared pre-accepted under such special conditions.
- (iii) during the compatibility process a declaration can be requested by the Terminal to confirm acceptances and fulfilment of such special conditions.
- (iv) It is responsibility of Terminal user as well as of the shipowner/operator calling at the Terminal to ensure that every time the ship is chosen to discharge at the OLT Terminal all the above conditions are permanently fulfilled by the vessel concerned over the entire mooring and unmooring procedure. Vessel owner, operator and user concerned remain all cumulatively responsible for the accuracy, correctness and completeness of the data used by the Terminal operator for the calculation.

Based on the above, once accepted, the vessel concerned will be declared pre-accepted under special Cargo conditions and it will be listed in the pre-accepted vessels list under a separate and dedicated sheet showing the conditions to be met by the same vessel for terminal acceptance. The publication of such information does not exempt the vessel owner or operator to inform the terminal user concerned about the actual acceptance conditions.

LNG Carrier Approval &Vetting Procedures

tug positon aft as much as possible from center
bitts no less of 100 t SWL-when possible preferable to connect at 200 swl Strong point
PREFERIBLE NO INTRFERENCES WITH MOORING LINES

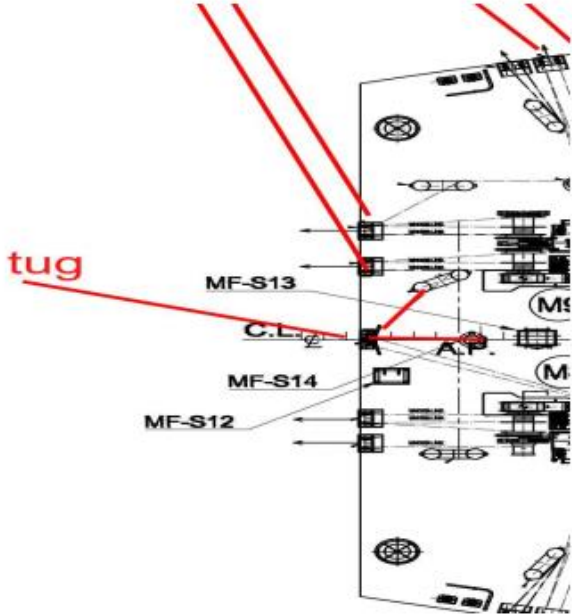

Tug positioion FWD
BITTS NO LESS OF 100T swl
preferible clear from mooring lines

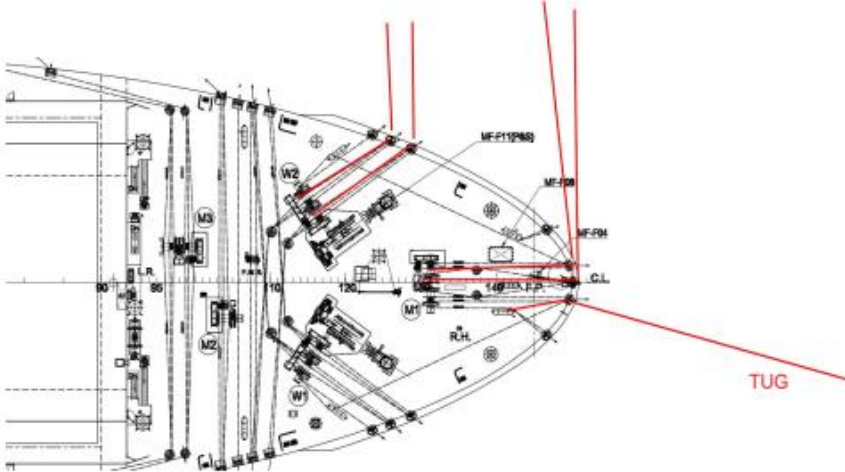

OLT Offshore LNG Toscana SpA - FSRU TOSCANA @ LIVORNO Compatibility Template to be filled by LNGC Owner/Operator in all parts in accordance to chapter 2.2 of regasification code of the OLT terminal

TV mooring arrangement
4 design requirements

mooring lay out requested by terminal

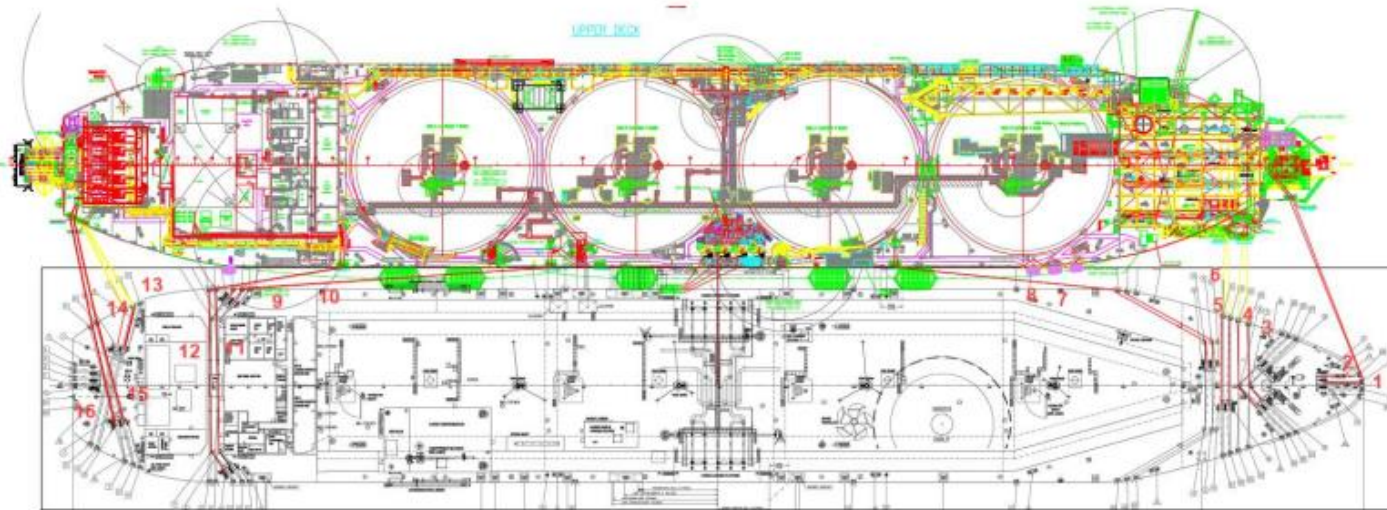

Design Mooring lay out optimum (requested by terminal)

- N°16 Mooring lines;
- N°4 aft spring lines from flat side (same lengths);
- Stern line passed from port aft fairlead (in order to avoid clash on stern corner);
- Bow lines (N°1,2) passed from fwd port fairlead (in order to avoid contact with extreme bow);
- N°2 fwd spring lines from flat side;
- Only mooring line from winch.

OLT Offshore LNG Toscana SpA - FSRU TOSCANA @ LIVORNO Compatibility Template to be filled by LNGC Owner/Operator in all parts in accordance to chapter 2.2 of regasification code of the OLT terminal

IV mooring arrangement
4.1

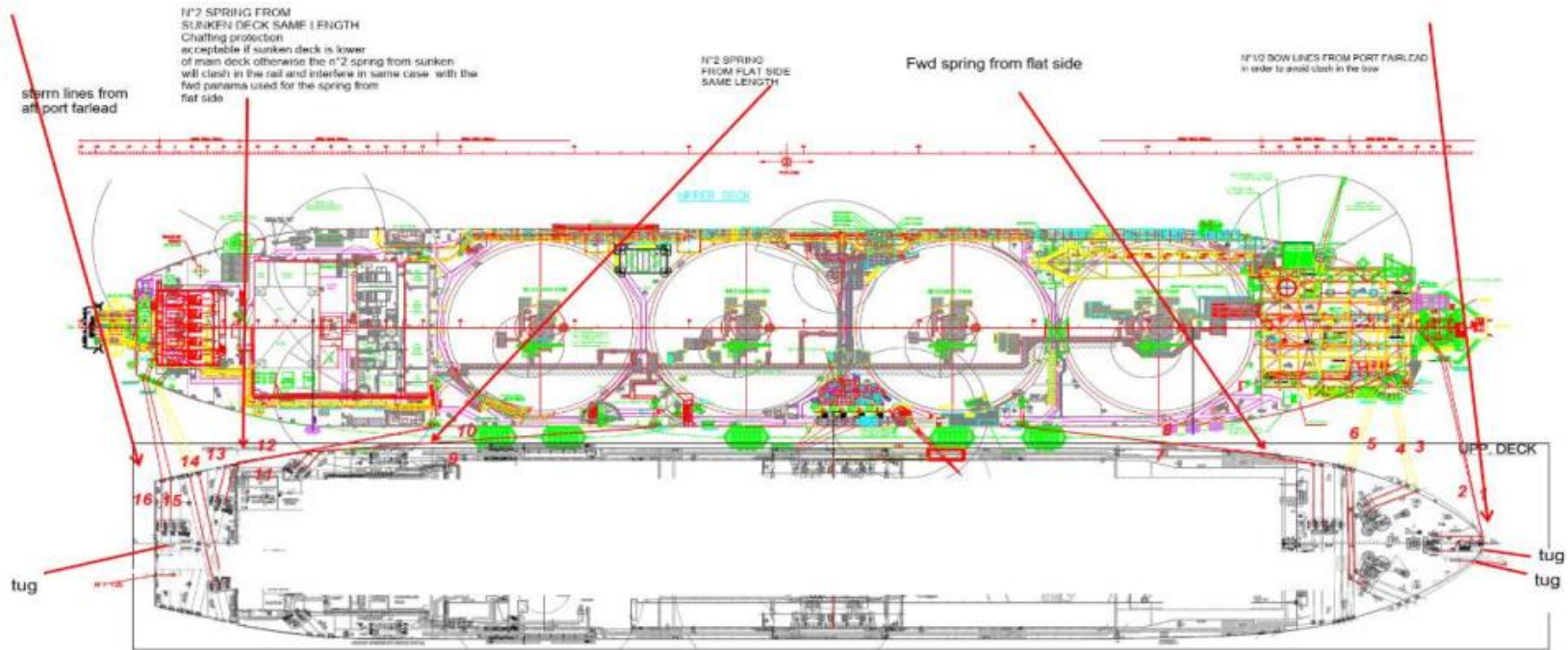

Option 1 (if the vessel is not able not to pass n°4 aft springs from flat side)

- N°16 mooring lines;
- N° 2 aft spring from flat side (same lengths);
- N°2 aft spring from sunken deck (same length, chafing protections necessary) in order to avoid clash in the rail and interferences with the other two fairleads used for the N°2 spring lines from flat side The sunken deck elevation must be lower of main deck.
- Stern lines passed from port aft fairlead (in order to avoid any clash on stern corner);
- Bow lines (N°1,2) passed from fwd port fairlead (in order to avoid contact with extreme bow);
- N°2 fwd spring lines from flat side;
- Only mooring lines from winch.

bits for tug no less of 100 t
position as indicate in the drawing

LNG Carrier Approval & Vetting Procedures

OLT Offshore LNG Toscana SpA - FSRU TOSCANA @ LIVORNO Compatibility Template to be filled by LNGC Owner/Operator in all parts in accordance to chapter 2.2 of regasification code of the OLT terminal

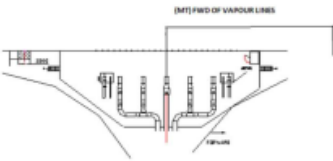
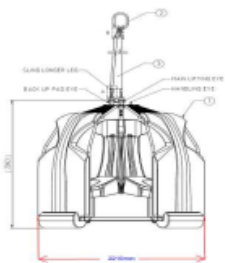
Items	Toscana-Shore Specification	Ship Specification	Remarks	Confirm Result
<p>V. Gangway / Support 1. Personnel transfer</p>	<p>1. Gangway Position (unit : m)</p> <p>Gangway not allowed Only basket is allowed</p> <p>A personnel basket attached to the man ridding crane at the manifold of the FSRU, assistance from LNGC crew will be required. Please refer to the Terminal Operating Procedures.</p> <div style="border: 1px solid black; padding: 5px; margin: 5px 0;"> <p style="text-align: center; font-size: x-small;">TARGETING SPOOL TRANSFER CAGE</p>  <p style="font-size: x-small;">Overall dimensions: 900 x 1200 x 180 mm Edge weight: approx. 250 kg Targeting system net weight: 435kg Targeting spool pieces interface: 16" Flanged ANSI B20</p> </div>	<p>1. Personnel transfer basket area (unit : m)</p> <p>1-Insert drawing showing landing area of transfer basket on main deck as below: Personal basket area to be located fwd of manifold vapour lines indicate how many meters . Terminal loading arms crane will be used.</p> 		
<p>2. Targeting spool piece Landing area</p>		<p>2-Insert drawing showing storage area for N°4 Targeting spool pieces cages N° 4 Spool pieces cages shall be load on board before the manoeuvring with ship crane from escort tugs and stored in a adequate position on board the LNGC . The spool pieces shall be removed one by one from the cage and transferred to the manifold platform for the installation.</p>		

LNG Carrier Approval & Vetting Procedures

OLT Offshore LNG Toscana SpA - FSRU TOSCANA @ LIVORNO Compatibility Template to be filled by LNGC Owner/Operator in all parts in accordance to chapter 2.2 of regasification code of the OLT terminal

Items	Toscana-Shore Specification	Ship Specification	Remarks	Confirm Result
VI. Loading Arm / Cargo Pump 1. Loading Arm (1) Flow Rate (2) Numbers (3) Size (4) Quick Release Coupler (5) Flange Spec. a. Flange (6) Strainer Mesh	1. Loading Arm Information (1) Vapour : 5.000 m ³ /h / arm Liquid : 17.500 m ³ /h / arm (2) Liquid : 2 Liquid / Vapour : 1 Vapour : 1 (3) 16 inches (4) Type : QCDC (hydraulic) and perc (5) (Terminal) a. Liquid: ANSI 150/16/RF Vapour : ANSI 150/16/RF Targeting spool pieces to be connected at lngc manifold (liquid 1,2,v,3) SEE APPENDIX IV (6) 60 MESH STN STL Supported teflon	1. Pump Spec. (1) Main Cargo : m ³ / hr mLC sets Stripping / Spray : m ³ / hr mLC sets Em'cy Cargo : m ³ / hr mLC sets (2) Liquid: Liquid / Vapour : Vapour : (3) - Liquid : - Vapour : Pressure at the Manifold Flange : BARG MAX unload rate: mlc/h (4) N/A (5) Flange Spec. : [Specification, Dimensions of spool piece] a. Liquid: Vapour: b. Bolt: Nut: SDP: (6) Strainer : Cargo Custody System : Copy of calibration certificate. This in order to verify if the accuracy of level , temperature, and pressure gauging device is in accordance's to the iso standard . Please ref" FSRU Toscana - LNG and GAS quality and measurement Manual" to section 2.2 lng testing and measuring methods: selection of gauging devices. 2.2.1 -2.2.2- 2.2.3. Is the vessel equipped with gauging average system in order to work in an offshore environmental ? YES/NO CTMS accuracy for the offshore environmental (Please ref to "FSRU Toscana - LNG and GAS quality and measurement Manual" sect.2.3.2. Liquid Level for offshore environmental.) Measuring equipment shall make sure that the CTMS is able to compensate for dynamic movement while the LNG Carrier is moored at the Terminal. The internal level sampling rate of the CTMS shall be fast enough to enable an appropriate processing, resulting in above specified readings with time intervals of typically fifteen (15) seconds to be stable within CTMS accuracy limits. Such information shall be included as part of the LNG Carrier calibration already approved by a qualified surveyor YES/NO	Ships Reducer Details: Max arrival tank pressure 140 mbar gauge as per Access Code Terminal Manuals	

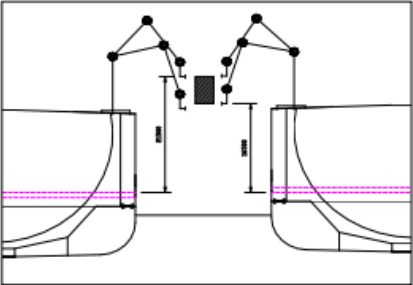
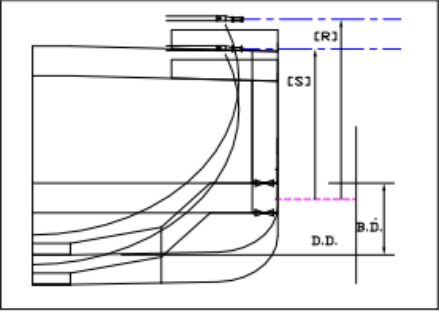
<p>2. Loading Arm Working Range</p> <p>j) Fuel Oil Arm k) MDO Arm l) Fresh Water Hose</p>	<p>2. Loading Arm Working Range</p> <p>VESSEL MANIFOLD ELEVATION MAX ACCEPTANCES</p> <p>(Max Manifold elevations is evaluated under ballast condition -heavy ballast may also be considered subject to a case by case evaluation)</p> <table border="1"> <thead> <tr> <th>Distance:</th> <th>MIN</th> <th>MAX</th> </tr> </thead> <tbody> <tr> <td>From ships side to manifold flange face:</td> <td>3,5</td> <td>4,0</td> </tr> <tr> <td>Between manifold centres [Y]</td> <td>2,5</td> <td>3,5</td> </tr> <tr> <td>Height above working platform</td> <td>0,9</td> <td>1,4</td> </tr> <tr> <td colspan="3">Vessel size -65k</td> </tr> <tr> <td>From centre line of manifold flange to S.W.L. 2.0m Hs</td> <td>16,5</td> <td>22,5*</td> </tr> <tr> <td colspan="3">Vessel size 138k</td> </tr> <tr> <td>From centre line of manifold flange to S.W.L. 2.5m Hs</td> <td>19,5</td> <td>21,5</td> </tr> <tr> <td>From centre line of manifold flange to S.W.L. 2.0m Hs Wave</td> <td>20,5</td> <td>22,5*</td> </tr> <tr> <td colspan="3">Vessel size 155k - 180K</td> </tr> <tr> <td>From centre line of manifold flange to S.W.L. 2.5m Hs</td> <td>19,5</td> <td>21,5</td> </tr> <tr> <td>From centre line of manifold flange to S.W.L. 2.0 m Hs</td> <td>20,5</td> <td>22,7*</td> </tr> </tbody> </table>  <p>Service Not Available</p> <p>Service Not Available</p> <p>Service Not Available</p> <p>*Vessel manifold elevation max acceptances</p>	Distance:	MIN	MAX	From ships side to manifold flange face:	3,5	4,0	Between manifold centres [Y]	2,5	3,5	Height above working platform	0,9	1,4	Vessel size -65k			From centre line of manifold flange to S.W.L. 2.0m Hs	16,5	22,5*	Vessel size 138k			From centre line of manifold flange to S.W.L. 2.5m Hs	19,5	21,5	From centre line of manifold flange to S.W.L. 2.0m Hs Wave	20,5	22,5*	Vessel size 155k - 180K			From centre line of manifold flange to S.W.L. 2.5m Hs	19,5	21,5	From centre line of manifold flange to S.W.L. 2.0 m Hs	20,5	22,7*	<p>2. Vessel Manifold Elevation</p> <p>Freeboard @ Ballast Draught = [FBD] 0 mm Freeboard @ Design Draught = [FDD] 0 mm</p> <p>Insert dimensions</p>  <p>Insert manifold elevation</p> <p>[S] CL Manifold above WL on arrival loaded @ DD = [MDD] draft MAN EL m [R] CL Manifold above WL on departure ballast @ BD = [MBD] m</p> <p>In case Heavy ballast is available insert CL Manifold above WL @ HBD = mm</p>	<p>LOADING ARMS ENVELOPE CALCULATION</p> <p>To be filled by Terminal</p> <table border="1"> <thead> <tr> <th colspan="2">Arrival - Connection:</th> </tr> </thead> <tbody> <tr> <td>Vessel draft on arrival</td> <td>0,0 m</td> </tr> <tr> <td>MDD</td> <td>0,00 m</td> </tr> <tr> <td>FSRU draft</td> <td>10,76 m</td> </tr> <tr> <td>Static flanging area =</td> <td>10,76 m</td> </tr> <tr> <td>FSRU Lower arm Limit</td> <td>25,32 m</td> </tr> <tr> <td>Static Margin lower limit</td> <td>-14,56 m</td> </tr> <tr> <td>Dynamic movement</td> <td>m</td> </tr> <tr> <td>Dynamic margin lower limit</td> <td>-14,56 m</td> </tr> </tbody> </table> <table border="1"> <thead> <tr> <th colspan="2">Departure-Disconnection:</th> </tr> </thead> <tbody> <tr> <td>Vessel draft @ Disconnection</td> <td>0,0 m</td> </tr> <tr> <td>MBD</td> <td>0,00 m</td> </tr> <tr> <td>FSRU draft</td> <td>12,3 m</td> </tr> <tr> <td>Static flanging area =</td> <td>12,30 m</td> </tr> <tr> <td>FSRU Higher arm Limit</td> <td>35,845 m</td> </tr> <tr> <td>Static flanging area =</td> <td>12,30 m</td> </tr> <tr> <td>Static Margin Upper limit</td> <td>23,545 m</td> </tr> <tr> <td>Dynamic movement</td> <td>m</td> </tr> <tr> <td>Dynamic margin upper limit</td> <td>23,545 m</td> </tr> </tbody> </table> <p>* To be change depending vessel size</p> <p>Note</p>	Arrival - Connection:		Vessel draft on arrival	0,0 m	MDD	0,00 m	FSRU draft	10,76 m	Static flanging area =	10,76 m	FSRU Lower arm Limit	25,32 m	Static Margin lower limit	-14,56 m	Dynamic movement	m	Dynamic margin lower limit	-14,56 m	Departure-Disconnection:		Vessel draft @ Disconnection	0,0 m	MBD	0,00 m	FSRU draft	12,3 m	Static flanging area =	12,30 m	FSRU Higher arm Limit	35,845 m	Static flanging area =	12,30 m	Static Margin Upper limit	23,545 m	Dynamic movement	m	Dynamic margin upper limit	23,545 m
Distance:	MIN	MAX																																																																											
From ships side to manifold flange face:	3,5	4,0																																																																											
Between manifold centres [Y]	2,5	3,5																																																																											
Height above working platform	0,9	1,4																																																																											
Vessel size -65k																																																																													
From centre line of manifold flange to S.W.L. 2.0m Hs	16,5	22,5*																																																																											
Vessel size 138k																																																																													
From centre line of manifold flange to S.W.L. 2.5m Hs	19,5	21,5																																																																											
From centre line of manifold flange to S.W.L. 2.0m Hs Wave	20,5	22,5*																																																																											
Vessel size 155k - 180K																																																																													
From centre line of manifold flange to S.W.L. 2.5m Hs	19,5	21,5																																																																											
From centre line of manifold flange to S.W.L. 2.0 m Hs	20,5	22,7*																																																																											
Arrival - Connection:																																																																													
Vessel draft on arrival	0,0 m																																																																												
MDD	0,00 m																																																																												
FSRU draft	10,76 m																																																																												
Static flanging area =	10,76 m																																																																												
FSRU Lower arm Limit	25,32 m																																																																												
Static Margin lower limit	-14,56 m																																																																												
Dynamic movement	m																																																																												
Dynamic margin lower limit	-14,56 m																																																																												
Departure-Disconnection:																																																																													
Vessel draft @ Disconnection	0,0 m																																																																												
MBD	0,00 m																																																																												
FSRU draft	12,3 m																																																																												
Static flanging area =	12,30 m																																																																												
FSRU Higher arm Limit	35,845 m																																																																												
Static flanging area =	12,30 m																																																																												
Static Margin Upper limit	23,545 m																																																																												
Dynamic movement	m																																																																												
Dynamic margin upper limit	23,545 m																																																																												



LNG Carrier Approval & Vetting Procedures

OLT Offshore LNG Toscana SpA - FSRU TOSCANA @ LIVORNO Compatibility Template to be filled by LNGC Owner/Operator in all parts in accordance to chapter 2.2 of regasification code of the OLT terminal

ITEMS	Toscana-Shore Specification	Ship Specification	Remarks	Confirm Result
<p>2. Loading Arm Working Range two discharge</p>	<p>Note Example : for vessel Size 158k -180k (or quantity to be discharge more of 158100 m3) if discharging full cargo are necessary two partial discharging.</p> <p>Terminal needs to know the vessel Draft in case it will be decided to perform two partial loadings e.g. the first loading load 125000cm with the LNGC remaining with about 48000 cbm/55000 + plus max ballast possible (one cargo tank full or two tanks partial filled or any other condition convenient for LNGC stability) .</p> <p>This draft is necessary in order to recalculate the envelope for first partial loading in disconnection and the reconnection for the second loading.</p> <p>The LNGC will be reconnected/moored when FSRU will have the sufficient space in the Cargo tank to load the remaining abt 48000 cm.8depending on vessel size we assume owner will prefer to depart with ones thankd full)</p>	<p>2. Vessel Manifold Elevation for 180 k vessel</p> <p>Optional: For quantity 158k -180k Cm3 (or quantity to be Discharge more of 158100m3)</p> <p>4th Discharge (175000 mm)</p> <p>LNGC Manifold Elevation: Lowest (S) = m Highest (R) = m</p> <p>Arrival - Connection: Vessel draft on arrival [] mm</p> <p>MDD [] mm</p> <p>+ FSRU draft 10760 mm</p> <p>Static flanging area = [] mm</p> <p>- FSRU Lower arm Limit 25320 mm</p> <p>Static Margin Upper limit [] mm</p> <p>Dynamic movement 790 mm</p> <hr/> <p>Departure-Disconnection: Vessel draft @ Disconnection [] mm</p> <p>+ MBD [] mm</p> <p>FSRU draft 12300 mm</p> <p>Static flanging area = [] mm</p> <p>FSRU Higher arm Limit 35845 mm</p> <p>Static flanging area = [] mm</p> <p>Static Margin Upper limit [] mm</p> <p>Dynamic movement 790 mm</p> <p>2nd Discharge (remaining cargo)</p> <p>Lowest (S) = m Highest (R) = m</p> <p>Arrival - Connection: Vessel draft on arrival [] mm</p> <p>MDD [] mm</p> <p>+ FSRU draft 10760 mm</p> <p>Static flanging area = [] mm</p> <p>- FSRU Lower arm Limit 25320 mm</p> <p>Static Margin Upper limit [] mm</p> <p>Dynamic movement 790 mm</p> <hr/> <p>Departure-Disconnection: Vessel draft @ Disconnection [] mm</p> <p>+ MBD [] mm</p> <p>FSRU draft 12300 mm</p> <p>Static flanging area = [] mm</p> <p>FSRU Higher arm Limit 35845 mm</p> <p>Static flanging area = [] mm</p> <p>Static Margin Upper limit [] mm</p> <p>Dynamic movement 790 mm</p>		

LNG Carrier Approval & Vetting Procedures

OLT Offshore LNG Toscana SpA - FSRU TOSCANA @ LIVORNO Compatibility Template to be filled by LNGC Owner/Operator in all parts in accordance to chapter 2.2 of regasification code of the OLT terminal

Items	Toscana-Shore Specification	Ship Specification	Remarks	Confirm Result																																																											
VII. Emergency Shut Down System																																																															
1. Optical Fiber System (1) Manufacture (2) Connector Type (3) Connection Box Position (4) Cable Length	1. Optical Fibre System (1) NFI-SeaTechnik (2) 6 Way F.O. connector (ST-Type) shore Type (Compatible with Furokawa /Sumitomo shipside equivalent) (3) 2.3m fwd of arm No1. (4) 50 m On reel (5) 5=Spare 6=Spare	1. Optical Fiber System Ship pin assigned (1) 1 (2) 2 (3) 3 (4) 4 (5) 5 (6) 6	Terminal connector (Shore type) 	1. OK																																																											
					2. Pneumatic System (1) Manufacture (2) Connector Type (3) Connection Box Position (4) Air Pressure Set Trip	2. Pneumatic System (1) Nitta moore (2) Snaplite Self Sealing Connector – Type QDC H-8- threaded coupler 1/4" BSP (3) Loading arm (4) Max 5 Bar The trip can be changed according with LNGC. The limitation is only maximum air set pressure which is 5 bar, it can be reduced but not increased. (5) m	FsrU Connector Male on fsru side fixed system . Female on pneumatic hose 	2. OK																																																							
									3. Electric System (1) Manufacture (2) Connector Type (3) Connection Box Position (4) Cable Length	3. Electric System (1) NFI-SeaTechnik (2) Pyle National 37 pin male connector (3) 1.25m fwd of arm No1. (4) 50 m reel	FSRU Assignments Electric (Pylw) PR6 (PINS 11-12) NOT IMPLEMENTED : <table border="1" style="font-size: x-small; border-collapse: collapse;"> <thead> <tr> <th>Pairs</th> <th>Pins</th> <th>Assignments</th> </tr> </thead> <tbody> <tr><td>Pv1</td><td>1,2</td><td>Spare</td></tr> <tr><td>Pv2</td><td>3,4</td><td>Spare</td></tr> <tr><td>Pv3</td><td>5,6</td><td>Hot phone</td></tr> <tr><td>Pv4</td><td>7,8</td><td>Public Phone</td></tr> <tr><td>Pv5</td><td>9,1</td><td>Plant Phone</td></tr> <tr><td>Pv6</td><td>11,1</td><td>4-20mA signal vapour line press</td></tr> <tr><td>Pv7</td><td>13,1</td><td>ESD FSRU to SHIP</td></tr> <tr><td>Pv8</td><td>15,2</td><td>ESD SHIP – FSRU</td></tr> <tr><td>Pv9</td><td>17,2</td><td>Continuity Check Link on Ship</td></tr> <tr><td>Pv10</td><td>19,2</td><td>Continuity Check Link on Ship</td></tr> <tr><td>Pv11</td><td>21,2</td><td>Spare Unused</td></tr> <tr><td>Pv12</td><td>23,2</td><td>Spare Unused</td></tr> <tr><td>Pv13</td><td>25,3</td><td>Spare Unused</td></tr> <tr><td>Pv14</td><td>27,3</td><td>Spare Unused</td></tr> <tr><td></td><td>29</td><td>IS=24V Supply For ETU</td></tr> <tr><td></td><td>30</td><td>IS 0V Supply For ETU</td></tr> <tr><td>Pv15</td><td>31,32,33</td><td>MLM RS 232 Signal</td></tr> <tr><td>Pv16</td><td>34,4</td><td>Spare</td></tr> <tr><td>Pv17</td><td>36,4</td><td>Spare</td></tr> </tbody> </table>	Pairs	Pins	Assignments	Pv1	1,2	Spare	Pv2	3,4	Spare	Pv3	5,6	Hot phone	Pv4	7,8	Public Phone	Pv5	9,1	Plant Phone	Pv6	11,1	4-20mA signal vapour line press	Pv7	13,1	ESD FSRU to SHIP	Pv8	15,2	ESD SHIP – FSRU	Pv9	17,2	Continuity Check Link on Ship	Pv10	19,2	Continuity Check Link on Ship	Pv11	21,2	Spare Unused	Pv12	23,2	Spare Unused	Pv13	25,3	Spare Unused	Pv14	27,3	Spare Unused		29	IS=24V Supply For ETU		30	IS 0V Supply For ETU	Pv15
Pairs	Pins	Assignments																																																													
Pv1	1,2	Spare																																																													
Pv2	3,4	Spare																																																													
Pv3	5,6	Hot phone																																																													
Pv4	7,8	Public Phone																																																													
Pv5	9,1	Plant Phone																																																													
Pv6	11,1	4-20mA signal vapour line press																																																													
Pv7	13,1	ESD FSRU to SHIP																																																													
Pv8	15,2	ESD SHIP – FSRU																																																													
Pv9	17,2	Continuity Check Link on Ship																																																													
Pv10	19,2	Continuity Check Link on Ship																																																													
Pv11	21,2	Spare Unused																																																													
Pv12	23,2	Spare Unused																																																													
Pv13	25,3	Spare Unused																																																													
Pv14	27,3	Spare Unused																																																													
	29	IS=24V Supply For ETU																																																													
	30	IS 0V Supply For ETU																																																													
Pv15	31,32,33	MLM RS 232 Signal																																																													
Pv16	34,4	Spare																																																													
Pv17	36,4	Spare																																																													
Ship must configure The pin arrangement To be compatible with terminal (confirm) YES/NO		4. N/A																																																													
ESDS Activation 1. ESD-1	Activated By a) Manual push button (local / remote) b) High loading arm slew / apex angle c) Cascade from FSRU ESDO d) Confirmed gas detection in the loading area e) Ship ESD f) FSRU storage tanks – high level		Activated By (1) (2) (3) (4) (5)	Loading Arm Moving Area <table border="1" style="font-size: x-small; border-collapse: collapse;"> <thead> <tr> <th rowspan="2">Reference point of loading arm (Pylw) FSRU Side and structural clearance from FSRU to Flanging area</th> <th colspan="2">LNG 45°N, 140°E</th> <th colspan="2">LNG 45°W, 140°E</th> </tr> <tr> <th>Flanging area Lower limit</th> <th>Flanging area Higher limit</th> <th>Flanging area Lower limit</th> <th>Flanging area Higher limit</th> </tr> </thead> <tbody> <tr> <td>ESD FSRU</td> <td>From Spooling Line 4140</td> <td>4140</td> <td>4140</td> <td>4140</td> </tr> <tr> <td>ESD SHIP</td> <td>From Spooling Line 4140</td> <td>4140</td> <td>4140</td> <td>4140</td> </tr> <tr> <td>ESD Heave-off</td> <td>Along Spooling Line 3540</td> <td>4130</td> <td>3540</td> <td>4130</td> </tr> </tbody> </table>	Reference point of loading arm (Pylw) FSRU Side and structural clearance from FSRU to Flanging area	LNG 45°N, 140°E		LNG 45°W, 140°E		Flanging area Lower limit	Flanging area Higher limit	Flanging area Lower limit	Flanging area Higher limit	ESD FSRU	From Spooling Line 4140	4140	4140	4140	ESD SHIP	From Spooling Line 4140	4140	4140	4140	ESD Heave-off	Along Spooling Line 3540	4130	3540	4130	1. OK																																		
Reference point of loading arm (Pylw) FSRU Side and structural clearance from FSRU to Flanging area	LNG 45°N, 140°E		LNG 45°W, 140°E																																																												
	Flanging area Lower limit	Flanging area Higher limit	Flanging area Lower limit	Flanging area Higher limit																																																											
ESD FSRU	From Spooling Line 4140	4140	4140	4140																																																											
ESD SHIP	From Spooling Line 4140	4140	4140	4140																																																											
ESD Heave-off	Along Spooling Line 3540	4130	3540	4130																																																											

LNG Carrier Approval & Vetting Procedures

2. ESD-2

- g) Activation of fusible links at tank dome
- h) Confirmed fire detection in loading area.
- i) Black out
- j) Control air – low pressure
- k) Cargo valve hydraulics - low pressure
- l) Activation of aft foam or engine room CO₂ systems

Effect:

- i) FRSU ESD
- ii) Audible alarm
- iii) ESD signal to ship

Activated By

- a) Manual push button (local / remote)
- b) Excessive loading arm slew / apex angle

Effect:

- i) Audible alarm
- ii) PERC Valves Closed (timed)
- iii) Disconnection of loading arms by PERC (timed)

- (6)
- (7)
- (8)
- (9)

ESD-2	From	To	To	To	To
ESD-2 (FT)	From Spooling Line	4950	4950	4950	4950
ESD-2 (Overhead)	Along Spooling Line	3300	4950	3300	3300
Mechanical Seal FWD	From Spooling Line	0030	0030	0030	0030
Mechanical Seal AFT	From Spooling Line	0030	0030	0030	0030
Mechanical Seal Starboard	Along Spooling Line	0030	1430	0030	0340

LOADING ARM ESD LIMITS AND MECHANICAL LIMITS BASED FOR A 135000 d3 LNG CARRIER						
Reference point #	ESD-2	Per-1 hr				Per-2 hr
		Flaring area	Flaring area	Flaring area	Flaring area	
ESD1 (AFT)	From Spooling Line	4300	4300	4300	4300	
ESD1 (Overhead)	Along Spooling Line	2700	3300	2700	2700	
ESD2 (AFT)	From Spooling Line	1700	1700	1700	1700	
ESD2 (Overhead)	Along Spooling Line	0200	0000	0200	0000	
Mechanical Seal FWD	From Spooling Line	0000	0000	0000	0000	
Mechanical Seal AFT	From Spooling Line	0000	0000	0000	0000	
Mechanical Seal Starboard	Along Spooling Line	0000	0000	0000	0000	

LOADING ARM ESD LIMITS AND MECHANICAL LIMITS BASED FOR A 100000 d3 LNG CARRIER						
Reference point #	ESD-2	Per-1 hr				Per-2 hr
		Flaring area	Flaring area	Flaring area	Flaring area	
ESD1 (AFT)	From Spooling Line	1000	1000	1000	1000	
ESD1 (Overhead)	Along Spooling Line	0000	0000	0000	0000	
ESD2 (AFT)	From Spooling Line	0700	0700	0700	0700	
ESD2 (Overhead)	Along Spooling Line	0000	0000	0000	0000	
Mechanical Seal FWD	From Spooling Line	0000	0000	0000	0000	
Mechanical Seal AFT	From Spooling Line	0000	0000	0000	0000	
Mechanical Seal Starboard	Along Spooling Line	0000	0000	0000	0000	

LOADING ARM ESD LIMITS AND MECHANICAL LIMITS BASED FOR A 100000 d3 LNG CARRIER						
Reference point #	ESD-2	Per-1 hr				Per-2 hr
		Flaring area	Flaring area	Flaring area	Flaring area	
ESD1 (AFT)	From Spooling Line	1000	1000	1000	1000	
ESD1 (Overhead)	Along Spooling Line	0000	0000	0000	0000	
ESD2 (AFT)	From Spooling Line	0700	0700	0700	0700	
ESD2 (Overhead)	Along Spooling Line	0000	0000	0000	0000	
Mechanical Seal FWD	From Spooling Line	0000	0000	0000	0000	
Mechanical Seal AFT	From Spooling Line	0000	0000	0000	0000	
Mechanical Seal Starboard	Along Spooling Line	0000	0000	0000	0000	

2. N/A

LNG Carrier Approval & Vetting Procedures

OLT Offshore LNG Toscana SpA - FSRU TOSCANA @ LIVORNO Compatibility Template to be filled by LNGC Owner/Operator in all parts in accordance to chapter 2.2 of regasification code of the OLT terminal

Items	Toscana-Shore Specification	Ship Specification	Remarks	Confirm Result
XI. Fire Fighting System	FSRU for own use has available resources: a) Gas detection b) Dry powder c) Water curtain d) Water monitors e) Fire fighting vessels are available	(1) (2) (3) (4) (5)	DP = Dry powder SW = sea water WS = Water spray WC = Water curtain FE = Foam extinguisher WM = Water Monitor	
XII. BOG Compressor (1) Number (2) Capacity (3) Pressure	1 RATED CAPACITY :13785 M3/H			
XIII. JETTY FLARE	(1) N/A			
XIV. Limitation of Wind Speed and Current Speed	Refer to latest terminal manual.			
XV. Approaching Speed Meter (1) Position (2) Manufacture (3) Specification (4) Type	232,85 1) On FSRU Pilot/Loading master Tablets to bring on board LNGC + batteries and UHF antenna 2) D'Appolonia 3) Box dimension : Exterior (L x W x D): 18.63 x 9.25" x 16.50 (47.3 x 23.5 x 41.9 cm), UHF band between 910 and 920 MHZ 4) DGPS + MRU			

LNG Carrier Approval & Vetting Procedures

OLT Offshore LNG Toscana SpA - FSRU TOSCANA @ LIVORNO Compatibility Template to be filled by LNGC Owner/Operator in all parts in accordance to chapter 2.2 of regasification code of the OLT terminal

Items	Toscana-Shore Specification	Ship Specification	Remarks	Confirm Result
XVI. Service	As Per terminal manual	Operating range of manifold cranes Port: Range SWL STB: Range SWL		
XVIII. Water Level	Terminal floating storage located in 112 m depth.(ref nautical chart)			

APPENDIX I

Appendix 1: ARRANGEMENT OF SHIP'S PARALLEL BODY AND FENDERS.

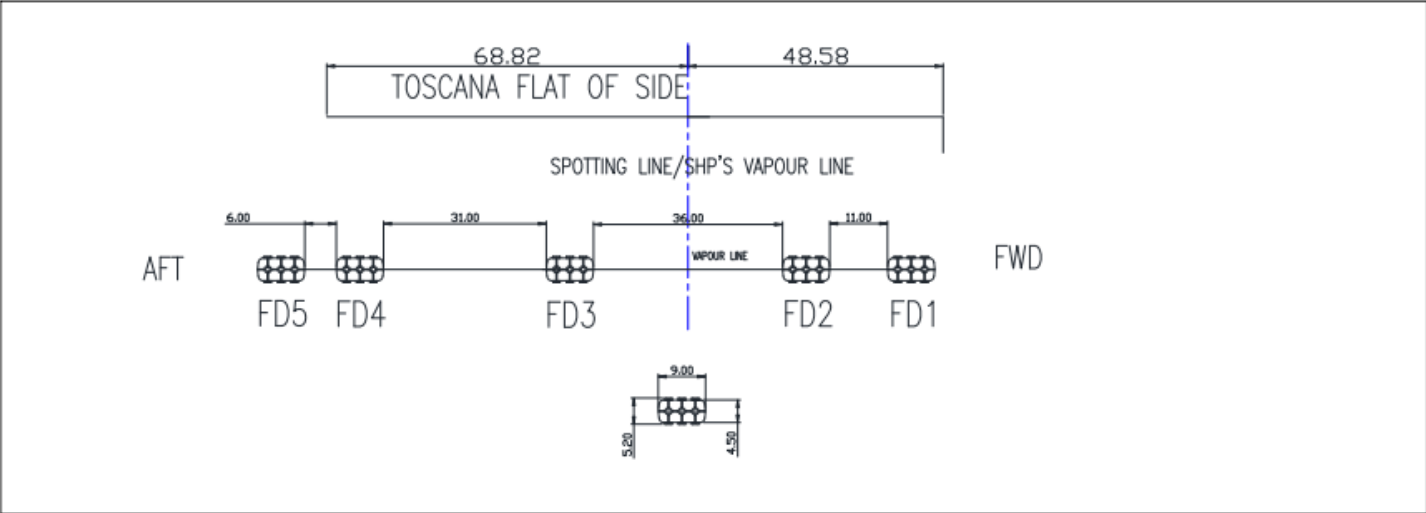

LNG Carrier Approval & Vetting Procedures

SpA - FSRU TOSCANA @ LIVORNO Compatibility Template to be filled by LNGC Owner/Operator in all parts in accordance to chapter 2.2 of regasification code of the OLT terminal

Appendix 2: LAYOUT OF QR HOOKS and CHOCKS.

FSRU TOSCANA

ALONGSIDE: PORT SIDE
 FSRU DEPTH MOULDED 26.5m LOADED DRAUGHT 12.3m BALLAST DRAUGHT 10.76m
 QR HOOKS 9 x DOUBLE 112 TONNES SWL
 SUNKEN DECK 3.7m BELOW MAIN DECK

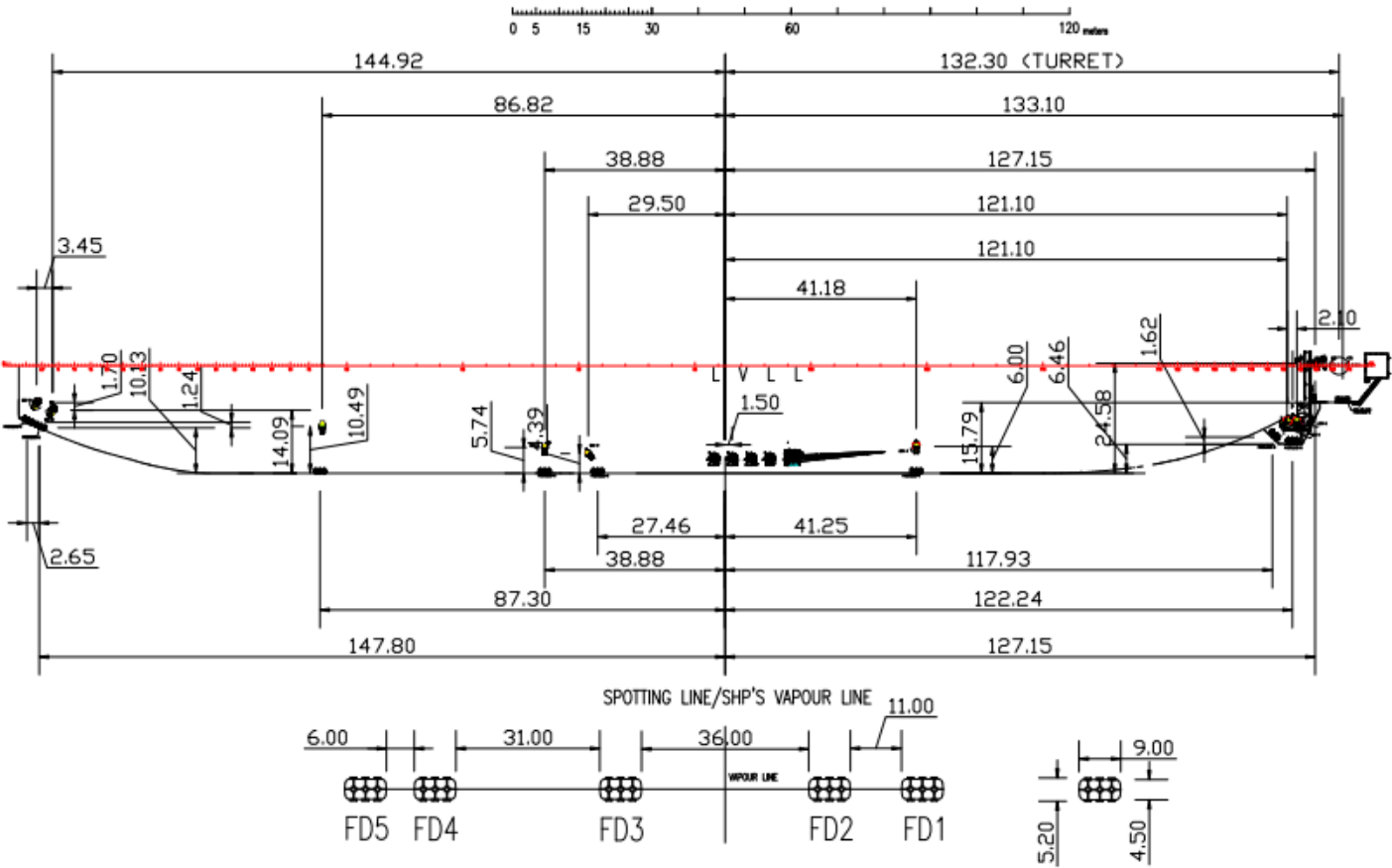

OLT Offshore LNG Toscana SpA - FSRU TOSCANA @ LIVORNO Compatibility Template to be filled by LNGC Owner/Operator in all parts in accordance to chapter 2.2 of regasification code of the OLT terminal

Appendix 3: BERTHING ENERGY AND STATIC MOORING CALCULATIONS.

OLT Offshore LNG Toscana SpA - FSRU TOSCANA @ LIVORNO Compatibility Template to be filled by LNGC Owner/Operator in all parts in accordance to chapter 2.2 of regasification code of the OLT terminal

Appendix 4: LNGC Manifold Free Space Envelope for fitting of the FSRU n° 4 MLA Targeting Spool Pieces directly connected at LNGC Manifold (without LNGC

FSRU Targeting spool to be used on OCIMF/SIGTTO CAT B. MANIFOLD ONLY

(Marine Loading Arms targeting spools consists of four (4) ship left spool kit for target system with Class certification, for assembly on 16" ANSI#150 Flanges built for connection to 4 no. FMC LNG Marine Loading Arms (FMC Ref: RA 07 1212). Each Spool piece will include the following:
 -16" #150 spool (Passivated 304 SST).-Cone. Passivated 304 SST-- Cable locking device.-- Bolting for assembly on 16" ANSI#150 Flanges. -- One gasket to be mounted between manifold and spool-Material; grade (304 SST))
 Vessel owner to verify and confirm if targeting spool pieces can be connected directly with manifold flanges as described in the pictures below.
 Please refer also to pages from 14 to 19 for additional information about targeting spool measurement.
 Please note that the use of MLA targeting spool pieces is essential in order to connect the loading arms.
 The LNGC Owner/Operator shall also provide pictures and relevant dimensions of the carriers' manifolds to demonstrate the adequacy of space available to connect the MLA targeting spool pieces.
 (Ref to SIGTTO Recommendation for liquified gas carrier manifold ed 2018)
 At exposed locations, targeting devices may be need to be fitted to the manifold flange . Considerations should be given to allow sufficient clearances, around the manifold flange , for such device to be fitted

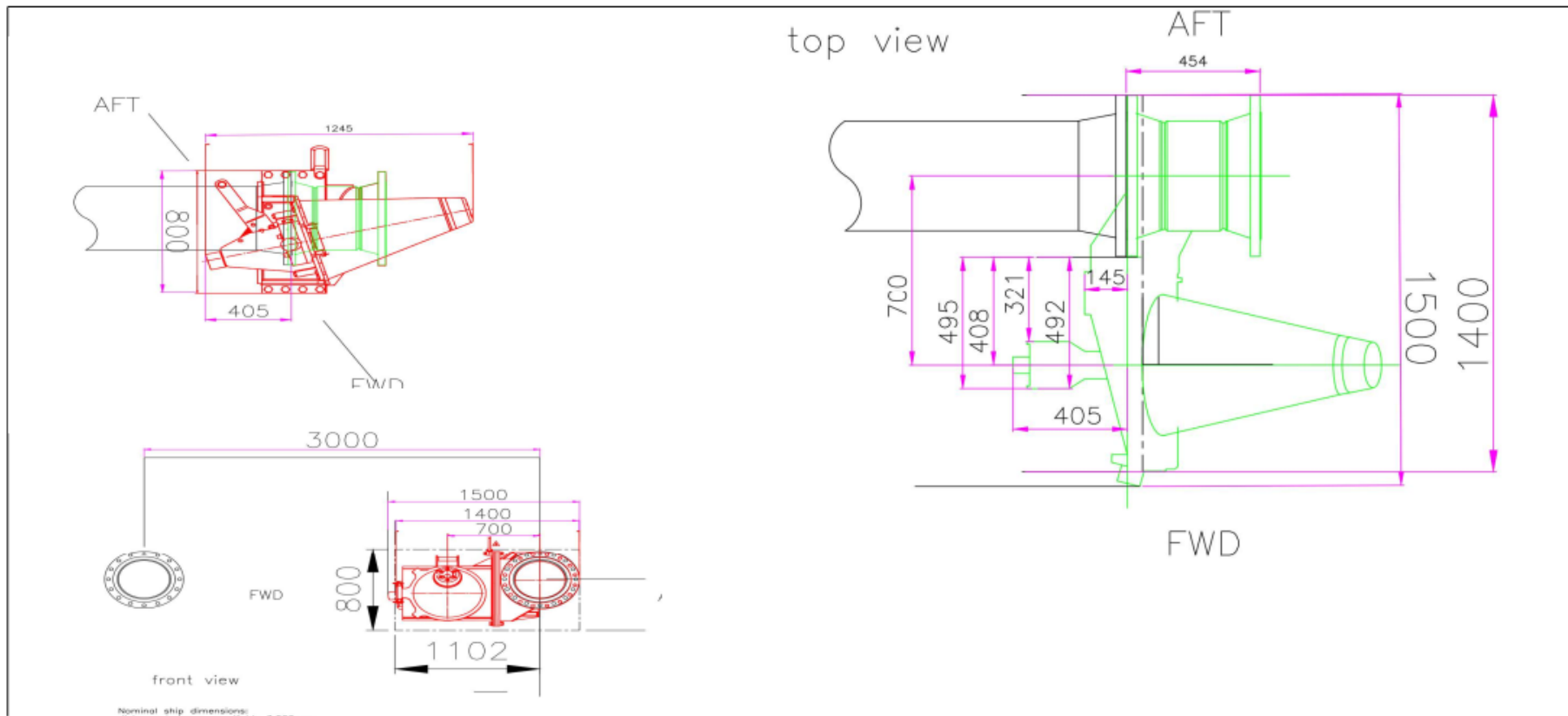

Port manifold- clearances necessary for targeting spool pieces installation (all manifold lines)

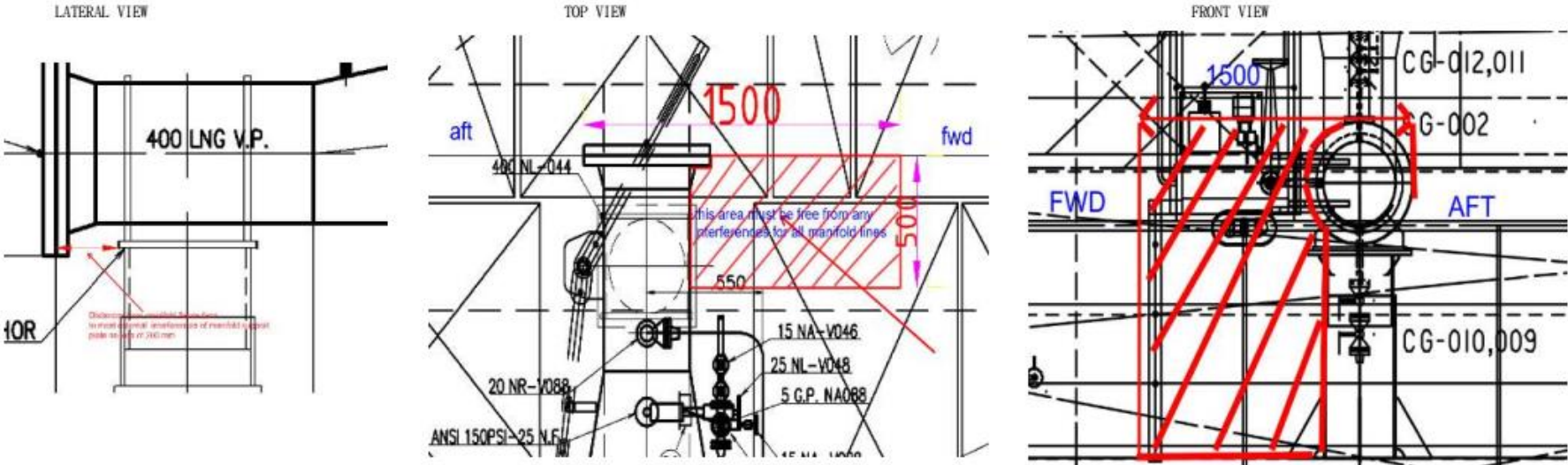

OLT Offshore LNG Toscana SpA - FSRU TOSCANA @ LIVORNO Compatibility Template to be filled by LNGC Owner/Operator in all parts in accordance to chapter 2.2 of regasification code of the OLT terminal

1- Vessel Owner/Operator to verify if there is sufficient space enough for the installation of MLA targeting spool pieces on manifold, any interference e.g. drip tray, valves, piping, etc. between the LNGC manifold and MLA Targeting spool pieces shall be avoided; Dimension and Pictures of MLA Targeting spool pieces attached.

MLA Targeting spool pieces connection using N° 8 x 220 mm and N° 8 x 175 mm M27 threaded bars provided by Terminal . Vessel to verify that gasket between manifold presentation flange and strainer not interfere with the M27 bars when inserted otherwise other gasket should be used. Normally this problem we experienced with vessel equipped with metaflex .
VESSEL TO USE NIPPON PILLAR #6631 SIZE 512X430X1.16mm (-400A 16")



MLA Targeting Spool pieces configuration when connected at LNGC manifolds liquid 1, liquid 2 vapour and liquid 3

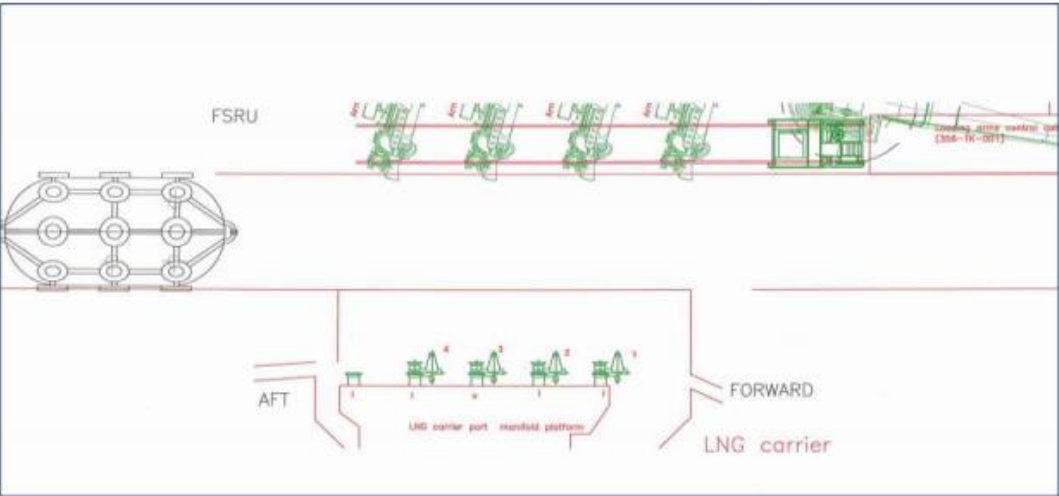

The transfer and installation of MLA targeting spool pieces is under the LNGC Operator responsibility under the supervision of Terminal Berthing Loading Master (BML).

OLT Offshore LNG Toscana SpA - FSRU TOSCANA @ LIVORNO Compatibility Template to be filled by LNGC Owner/Operator in all parts in accordance to chapter 2.2 of regasification code of the OLT terminal

TARGETING SPOOL PIECES SURFACE FLANGE CHARACTERISTIC AND PICTURES

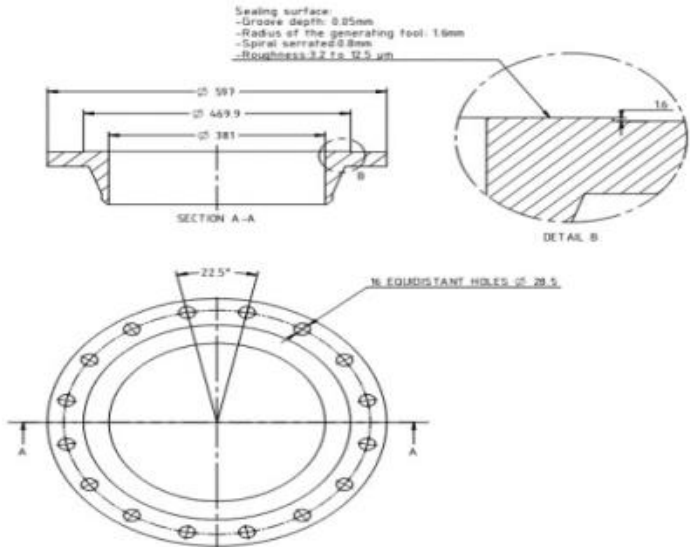
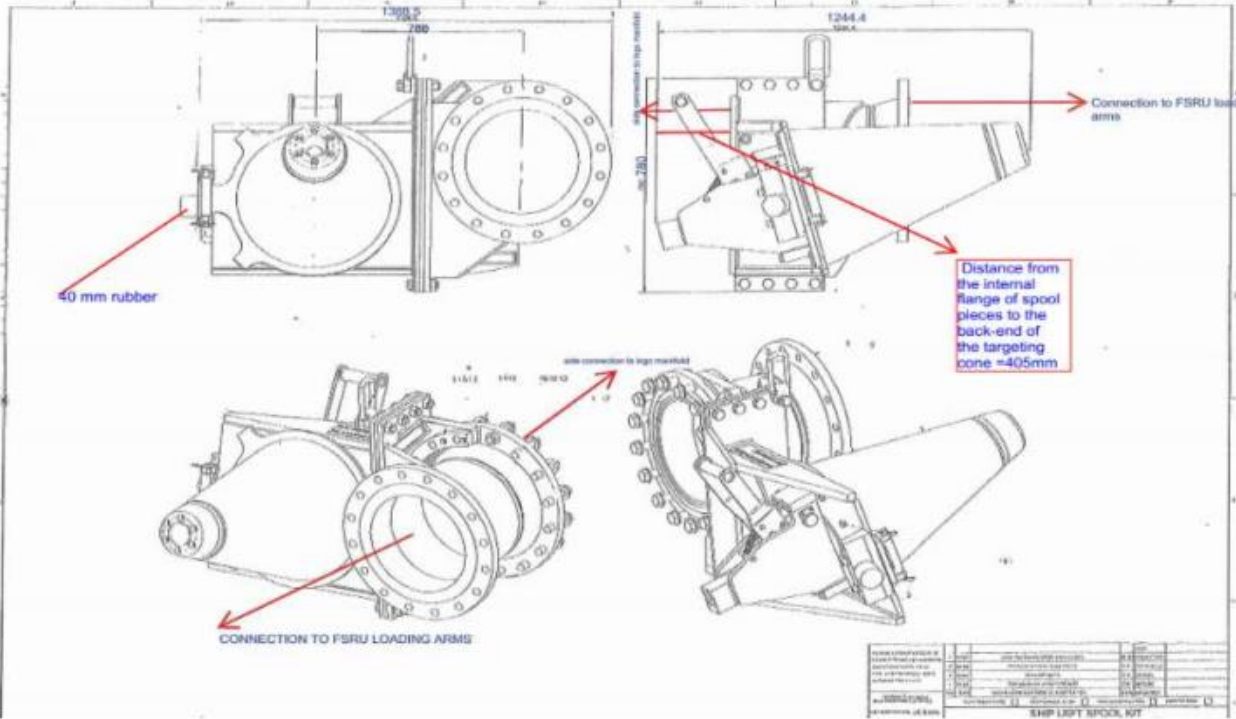





LNG Carrier Approval & Vetting Procedures





OLT Offshore LNG Toscana SpA - FSRU TOSCANA @ LIVORNO Compatibility Template to be filled by LNGC Owner/Operator in all parts in accordance to chapter 2.2 of regasification code of the OLT terminal

Appendix 4: LNGC Manifold Free Space Envelope for fitting of the FSRU n° 4 MLA Targeting Spool Pieces connected at LNGC Manifold with LNGC SDP (ref to SIGTTO manifold recommendation 2018 4.3)

The assumption used to provide the recommendations in section 4 are based on the use of marine loading arms and criteria below .

If a ship is to be operated outside the recommended criteria specified below

,then further engineering studies should be carried to ensure the manifold arrangement is not overstressed /overloaded

-Only ones reducer or spool pieces is connected to a distances pieces

In case the Marine Loading Arms targeting spools can not be connected directly to the LNGC manifolds due to the presence of interferences/obstructions, Vessel owner may request the connection to be done using a 350mm or 500mm LNGC SDP.

In order to make the connection by using a 350mm or 500mm LNGC SDP the LNGC Owner/Operator is informed that the Loading Arms' manufacturer has performed verification of the LNG Carrier manifold stress with SDP mounted for vessel between 65 k and 180k based on the following assumptions

- the allowable load values have been limited in combination for a calculated stress on standard pipe schedule equal or less the allowable stress level according to OCIMF 99/ EN 1474-1 / ISO 16904 (K xSd);
- the maximum allowable loads to be applied to the manifold were based on the result of a stress calculation made on a standard schedule pipe with mechanical characteristics equivalent to 304/316 types for stainless steel, a cantilever length of 1200 mm considered in the stress evaluation, manifold outside diameter 406.4mm, thickness 9.53mm, as described in the following TABLE;

Diameter	406,4	mm (16")
Thickness	9,53	mm (16")
Materials	ASTM A 312 Gr. TP 316/316L or 304/304L SML or ASTM A 358 Gr. TP 316/316L or 304/304L Class 1	

- The calculation of stress on a pipe is done by formula combining the following components: Axial load, Radial load (resultant value), Bending moment (resultant value), Internal pressure. Consequently the maximum stress on the manifold is calculated according to OCIMF99 and EN1474-1.

Based on the above LNGC Owner/Operator is required to provide a certificate of manifold pipes', manifold supports' and SDPs' conformity covering both material and dimensional conformity issued by yard, class or certified third parties.

If materials are different and/or dimensions are lower than the above assumed specifications a specific study shall be required at LNGC Owner/Operator's own costs to demonstrate that the LNG Carrier manifold stress complies with the applicable manifolds' load limits provided by SIGTTO Manifold Recommendations ed. 2011 (chapter 4.3). LNGC Owner/Operator shall also provide a certificate to demonstrate the material and dimensions of the manifold pipes, manifold supports and SDPs.

Considering the length of the cantilever (ship SDP + Terminal targeting spool pieces) in order to avoid possible leakage vessel owner must verify that the bolt and gasket used for the connection of the ship SDP ship to the manifold flange is adequate to bear a torque to Abt -900 nm.

(bolt and nuts material should be in accordance with Sigtto recommendations for liquified gas carrier Manifolds 4.2.3 Pag 27)

(Fastening :ASTM A320 B8M class 2(bolt)-ASTM A194 Gr 8M (Nut)-Washer SS316 size m27

ASTM A320 -Standard specification for alloy -Steel and Stainless Steel Bolting for low -Temperature Service

ASTM A194-Standard Specification for Carbon Steel ,Alloy Steel ,and Stainless Steel Nuts for bolts for high Pressure or high Temperature Service,or Both.

OLT Offshore LNG Toscana SpA - FSRU TOSCANA @ LIVORNO Compatibility Template to be filled by LNGC Owner/Operator in all parts in accordance to chapter 2.2 of regasification code of the OLT terminal

Bad weather departure

Appendix 5: Poor Weather Departure

Bad weather departure:

Please ref to Terminal regulation and information booklet chapter 4.3 "Partial fill operation for membrane LNG Carrier".

LNG Carrier Approval &Vetting Procedures

OLT Offshore LNG Toscana SpA - FSRU TOSCANA @ LIVORNO Compatibility Template to be filled by LNGC Owner/Operator in all parts in accordance to chapter 2.2 of regasification code of the OLT terminal

To be signed by LNGC Owner/Operator and Terminal Owner/Operator at conclusion of the compatibility process
The Vessel is considered pre-accepted considering passed successfully compatibility step 1,2 and will be inserted in the list according LNGC Carrier Approval & vetting procedure manual subject to the below point x-x-x-x if it will complete successfully after first call step 3,4), final acceptances visit and unloading test will be considered compatible for 36 month)

Signature

OLT Offshore LNG Toscana

Signature

Vessel Owner Operator

EDITION	DATE
16	30.05.2016
17	27.08.2016
18	04.10.2016
19	03.02.2017
20	11/03/2017
21	01/10/2017
22	06.12.2017
23	15/04/2018
24	04/12/2018
25	07/02/2019
26	01/03/2019
27	30/04/2019
28	24/06/2019
29	03/06/2020
30	14/07/2020

REVISION	DATE	NOTES
0		Blank form
1		
2		
3		